

PARTS LIST

Setting-up and Operating Instructions for

Taylor-Way

REG. U. S. PAT. OFF.

HYDRAULIC FOLDING FLEXIBLE WHEEL TANDEM HARROW

TRANSPORT WIDTH — 15'9"

Regreasable Ball Bearings

9" or 10½" Disc Spacing

1½" Square Axle

Model Number	No. of Discs	Size of Wings	Width of Cut	Approximate Weight					Suggested D.B.H.P.
				22" x 3/16" C.O.	22" x ¼" C.O.	24" x 3/16" C.O.	24" x ¼" C.O.	24" x 5/16" C.O.	
8" DISC SPACING									
200284	58	6F, 7R	20'8"	11,510	11,895	11,800	12,305	12,780	160
200285	66	8F, 9R	23'7"	12,365	12,805	12,695	13,285	13,610	180
200286	70	9F, 10R	25'0"	12,715	13,185	13,100	13,745	14,320	200
200287	74	10F, 11R	26'5"	13,435	13,925	13,815	14,465	15,070	220
200288	78	11F, 12R	27'10"	13,880	14,395	14,275	14,945	15,585	240
200289	82	12F, 13R	29'3"	14,310	14,855	14,725	15,425	16,100	260
200290	86	13F, 14R	30'8"	14,860	15,420	15,180	15,905	16,610	280
200291	90	14F, 15R	32'2"	15,150	15,750	15,610	16,385	17,125	300
10½" DISC SPACING									
200310	58	7F, 8R	24'0"	12,355	12,605	12,480	12,960	13,435	180
200311	62	8F, 9R	25'8"	12,695	12,980	12,830	13,345	13,850	200
200312	66	9F, 10R	27'2"	13,265	13,550	13,410	13,955	14,495	220
200313	70	10F, 11R	28'10"	13,460	13,760	13,615	14,195	14,770	240
200314	74	11F, 12R	30'6"	13,800	14,120	13,965	14,580	15,185	260
200315	78	12F, 13R	32'2"	13,985	14,330	14,165	14,810	15,460	280
10½" DISC SPACING FRONT 9" DISC SPACING REAR									
200320	62	7F, 9R	23'7"	12,695	12,960	12,830	13,345	13,850	180
200321	66	8F, 10R	25'0"	13,035	13,320	13,180	13,725	14,265	200
200322	72	9F, 12R	27'10"	13,755	14,070	13,915	14,515	15,105	220
200323	76	10F, 13R	29'3"	13,845	14,175	14,010	14,640	15,260	240
200324	80	11F, 14R	30'8"	14,190	14,535	14,365	15,030	15,685	260
200325	84	12F, 15R	32'2"	14,390	14,750	14,575	15,270	15,960	280

Above implements are shipped with one extra disc on outside of each rear wing. The outside discs on front wings are tapered 2" and the outside two discs on rear wings are tapered 2" and 4". Shipped with 15" x 10" Floatation Rims, six for Models 200284-286, eight for Models 200287-291. Use 11L x 15 Floatation Tires, not furnished. Shipped with two 4" x 24" double action Hydraulic Cylinders with hose and fittings for wings and two ASAE 5" x 8" double action Hydraulic Cylinders with hose and fittings for transport. Balk Breaker shipped as Standard Equipment.

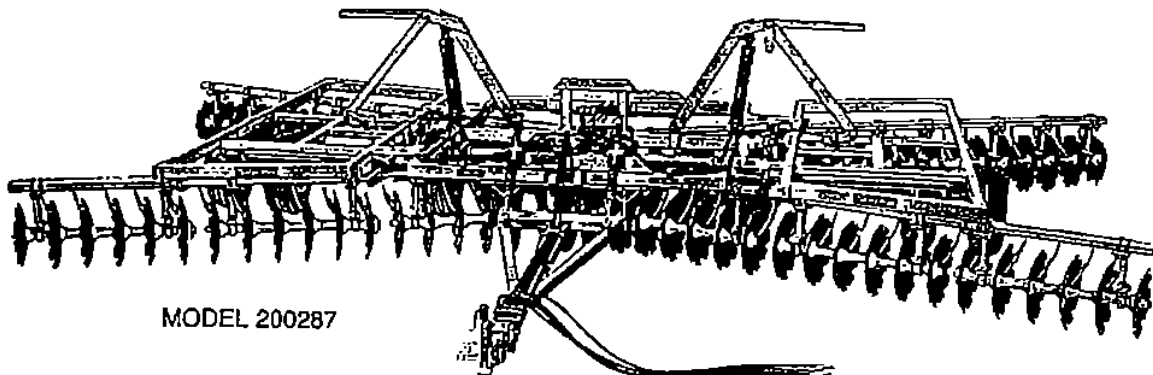

MODEL 200287

TAYLOR IMPLEMENT DIVISION
PITTSBURGH FORGINGS CO.
TRACTOR DRAWN *Taylor-Way* IMPLEMENTS
REG. U. S. PAT. OFF.

ATHENS, TENNESSEE 37303—TELEPHONE (AREA CODE 615) 745-3110

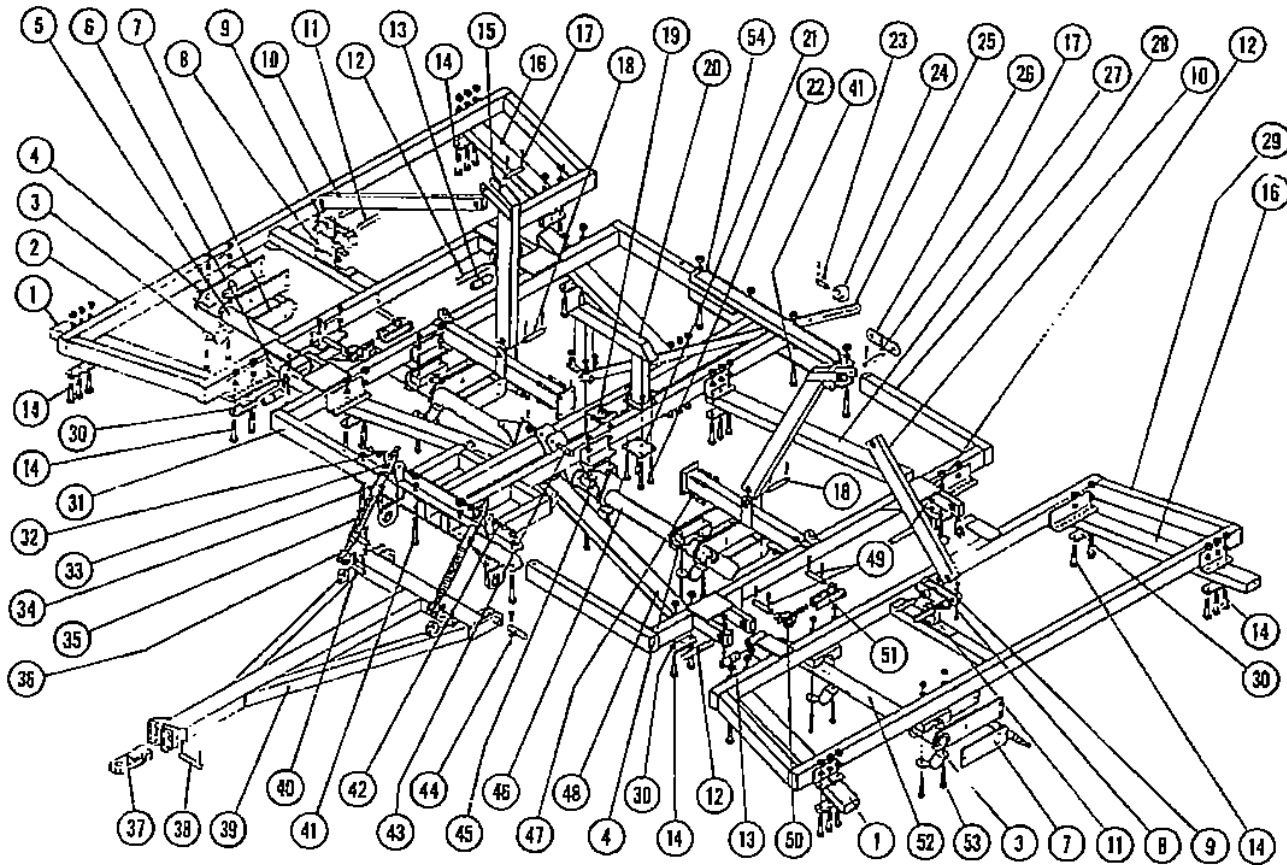

FIG. 1 — BASIC FRAME

Item No.	Part Number	FOR MODEL															Description	Size					
		200284	200295	200296	200297	200298	200299	200290	200291	200310	200311	200312	200313	200314	200315	200320			200321	200322	200323	200324	200325
1	208145	2	0	0	0	0	0	0	0	0	0	0	0	0	0	0	0	0	0	0	0	Front Wing Gang Tube	65"
	208147	0	2	0	0	0	0	0	0	2	0	0	0	0	0	2	0	0	0	0	0	Front Wing Gang Tube	70"
	208181	0	0	2	0	0	0	0	0	0	2	0	0	0	0	0	0	0	0	0	0	Front Wing Gang Tube	79"
	208466	0	0	0	2	0	0	0	0	0	0	2	0	0	0	0	2	0	0	0	0	Front Wing Gang Tube	88"
	208129	0	0	0	0	2	0	0	0	0	0	2	0	0	0	0	0	0	2	0	0	Front Wing Gang Tube	99"
	208150	0	0	0	0	0	2	0	0	0	0	0	0	0	0	0	0	0	0	0	0	Front Wing Gang Tube	106"
	208151	0	0	0	0	0	0	2	0	0	0	0	0	2	0	0	0	0	2	0	0	Front Wing Gang Tube	115"
	208152	0	0	0	0	0	0	0	2	0	0	0	0	0	2	0	0	0	0	0	2	Front Wing Gang Tube	124"
2	209762	1	1	1	0	0	0	0	0	1	1	0	0	0	0	1	1	0	0	0	0	Right Small Wing Frame	
	209764	0	0	0	1	1	1	1	1	0	0	1	1	1	1	0	0	1	1	1	1	Right Large Wing Frame	
	304194	2	2	2	2	2	2	2	2	2	2	2	2	2	2	2	2	2	2	2	2	Alemite (Straight)	1/8"
3	209236	8	8	8	8	8	8	8	8	8	8	8	8	8	8	8	8	8	8	8	8	Wheel Lift Strap	
4	209235	8	8	8	8	8	8	8	8	8	8	8	8	8	8	8	8	8	8	8	8	Wheel Lift Bearing	
	304194	8	8	8	8	8	8	8	8	8	8	8	8	8	8	8	8	8	8	8	8	Alemite (Straight)	1/8"
5	209393	1	1	1	0	0	0	0	0	1	1	0	0	0	0	1	1	0	0	0	0	Right Wing Wheel Lift	
	209395	0	0	0	1	1	1	1	1	0	0	1	1	1	1	0	0	1	1	1	1	Right Wing Wheel Lift	
6		4	4	4	4	4	4	4	4	4	4	4	4	4	4	4	4	4	4	4	4	Bolt w/Nut	1/2"x5"
	303955	4	4	4	4	4	4	4	4	4	4	4	4	4	4	4	4	4	4	4	4	Lock Washer	1/2"
	303971	8	8	8	8	8	8	8	8	8	8	8	8	8	8	8	8	8	8	8	8	Flat Washer	1/2"
7	209876	2	2	2	0	0	0	0	0	2	2	0	0	0	0	2	2	0	0	0	0	Single Wheel Axle	
	209877	2	2	2	4	4	4	4	4	2	2	4	4	4	4	2	2	4	4	4	4	Double Wheel Axle	
	303957	24	24	24	24	24	24	24	24	24	24	24	24	24	24	24	24	24	24	24	24	Bolt w/Nut	3/4"x2 3/4"
8		24	24	24	24	24	24	24	24	24	24	24	24	24	24	24	24	24	24	24	24	Lock Washer	3/4"
	303955	4	4	4	4	4	4	4	4	4	4	4	4	4	4	4	4	4	4	4	4	Bolt w/Nut	1/2"x2 3/4"
9	208101	2	2	2	2	2	2	2	2	2	2	2	2	2	2	2	2	2	2	2	2	Lock Washer	1/2"
10	208436	2	2	2	0	0	0	0	0	2	2	0	0	0	0	2	2	0	0	0	0	Rocker Arm	
	208117	0	0	0	2	2	2	2	2	0	0	2	2	2	2	2	2	0	0	0	0	Radius Arm	
11	208106	4	4	4	4	4	4	4	4	4	4	4	4	4	4	4	4	4	4	4	4	Radius Arm	
12	208039	4	4	4	4	4	4	4	4	4	4	4	4	4	4	4	4	4	4	4	4	Pin	1
13	208055	4	4	4	4	4	4	4	4	4	4	4	4	4	4	4	4	4	4	4	4	Wing Hinge Pin	1 3/8"x 1 3/4"
14		34	34	34	34	34	34	34	34	34	34	34	34	34	34	34	34	34	34	34	34	Wing Hinge Bushing	
	6	6	6	6	6	6	6	6	6	6	6	6	6	6	6	6	6	6	6	6	6	Bolt w/Nut, Grade 5	3/8"x5 1/2"
	303958	40	40	40	40	40	40	40	40	40	40	40	40	40	40	40	40	40	40	40	40	Bolt w/Nut, Grade 5	3/8"x7"
																						Lock Washer	3/8"

Item No.	Part Number	FOR MODEL															Description	Size					
		200284	200285	200286	200287	200288	200289	200290	200291	200310	200311	200312	200313	200314	200315	200320			200321	200322	200323	200324	200325
15	208107	2	2	2	2	2	2	2	2	2	2	2	2	2	2	2	2	2	2	2	2	Cylinder Arm	
	208863	2	2	2	2	2	2	2	2	2	2	2	2	2	2	2	2	2	2	2	2	Tension Bushing	1"IDx3/8"W
	208939	2	2	2	2	2	2	2	2	2	2	2	2	2	2	2	2	2	2	2	2	Bushing	
16	208146	2	0	0	0	0	0	0	0	0	0	0	0	0	0	0	0	0	0	0	0	Rear Wing Gang Tube	61"
	208148	0	2	0	0	0	0	0	0	0	0	0	0	0	2	0	0	0	0	0	0	Rear Wing Gang Tube	81"
	208149	0	0	2	0	0	0	0	0	0	0	0	0	0	0	0	0	0	0	0	0	Rear Wing Gang Tube	90"
	208129	0	0	0	2	0	0	0	0	0	0	0	0	0	0	0	0	0	0	0	0	Rear Wing Gang Tube	99"
	208150	0	0	0	0	2	0	0	0	0	0	0	0	0	0	0	0	0	0	0	0	Rear Wing Gang Tube	106"
	208151	0	0	0	0	0	2	0	0	0	0	0	0	0	0	0	0	0	0	0	0	Rear Wing Gang Tube	115"
	208152	0	0	0	0	0	0	2	0	0	0	0	0	0	2	0	0	0	0	0	0	Rear Wing Gang Tube	124"
	208153	0	0	0	0	0	0	0	2	0	0	0	0	0	0	2	0	0	0	0	0	Rear Wing Gang Tube	133"
17	208876	2	2	2	2	2	2	2	2	2	2	2	2	2	2	2	2	2	2	2	2	Pin	1 3/4"x7 3/4"
	303113	4	4	4	4	4	4	4	4	4	4	4	4	4	4	4	4	4	4	4	4	Klick Pin	
18	208115	2	2	2	2	2	2	2	2	2	2	2	2	2	2	2	2	2	2	2	2	Pin	1 3/8"x7"
	304151	4	4	4	4	4	4	4	4	4	4	4	4	4	4	4	4	4	4	4	4	Cotter	3/8"x2"
19	208027	2	2	2	2	2	2	2	2	2	2	2	2	2	2	2	2	2	2	2	2	Connector Plate	
20	208119	1	1	1	1	1	1	1	1	1	1	1	1	1	1	1	1	1	1	1	1	Wing Stop	
21	208122	2	2	2	2	2	2	2	2	2	2	2	2	2	2	2	2	2	2	2	2	Connector Plate	
22		8	8	8	8	8	8	8	8	8	8	8	8	8	8	8	8	8	8	8	8	Bolt w/Nut	3/4"x7 1/2"
	303957	8	8	8	8	8	8	8	8	8	8	8	8	8	8	8	8	8	8	8	8	Lock Washer	3/8"
23	208092	1	1	1	1	1	1	1	1	1	1	1	1	1	1	1	1	1	1	1	1	Depth Adjustment Pin	1 3/8"x3 3/8"
	304151	2	2	2	2	2	2	2	2	2	2	2	2	2	2	2	2	2	2	2	2	Cotter	3/8"x2"
24	208091	1	1	1	1	1	1	1	1	1	1	1	1	1	1	1	1	1	1	1	1	Depth Adjustment Cuff	
25	208088	1	1	1	1	1	1	1	1	1	1	1	1	1	1	1	1	1	1	1	1	Depth Bar	
26	208116	1	1	1	1	1	1	1	1	1	1	1	1	1	1	1	1	1	1	1	1	Wing Lock Plate	
27	208126	2	2	2	2	2	2	2	2	2	2	2	2	2	2	2	2	2	2	2	2	Rear Gang Tube, 8-Disc	71"
28	209760	1	1	1	1	1	1	1	1	1	1	1	1	1	1	1	1	1	1	1	1	Left Side Frame	
29	209763	1	1	1	0	0	0	0	0	1	0	0	0	0	1	0	0	0	0	0	0	Left Small Wing Frame	
	209765	0	0	0	1	1	1	1	1	0	0	1	1	1	0	0	1	1	1	1	1	Left Large Wing Frame	
	304194	2	2	2	2	2	2	2	2	2	2	2	2	2	2	2	2	2	2	2	2	Alemite (Straight)	3/8"
30	209768	16	16	16	16	16	16	16	16	16	16	16	16	16	16	16	16	16	16	16	16	Gang Connector Plate	
31	209759	1	1	1	1	1	1	1	1	1	1	1	1	1	1	1	1	1	1	1	1	Right Side Frame	
32	304053	2	2	2	2	2	2	2	2	2	2	2	2	2	2	2	2	2	2	2	2	Heavy Hex Nut	1 3/8"
33	206612	2	2	2	2	2	2	2	2	2	2	2	2	2	2	2	2	2	2	2	2	Compression Spring	
34	203742	2	2	2	2	2	2	2	2	2	2	2	2	2	2	2	2	2	2	2	2	Spring Rod Slide	
	304194	2	2	2	2	2	2	2	2	2	2	2	2	2	2	2	2	2	2	2	2	Alemite	3/8"
35	209148	2	2	2	2	2	2	2	2	2	2	2	2	2	2	2	2	2	2	2	2	Compression Spring	
36	209603	2	2	2	2	2	2	2	2	2	2	2	2	2	2	2	2	2	2	2	2	Spring Rod	
	205163	4	4	4	4	4	4	4	4	4	4	4	4	4	4	4	4	4	4	4	4	Special Washer	
37	209687	1	1	1	1	1	1	1	1	1	1	1	1	1	1	1	1	1	1	1	1	Double Drawbar Clevis	
38	209742	1	1	1	1	1	1	1	1	1	1	1	1	1	1	1	1	1	1	1	1	Clevis Pin	
	304165	2	2	2	2	2	2	2	2	2	2	2	2	2	2	2	2	2	2	2	2	Cotter	1/2"x3"
39	209605	1	1	1	1	1	1	1	1	1	1	1	1	1	1	1	1	1	1	1	1	Tongue	
40	203100	2	2	2	2	2	2	2	2	2	2	2	2	2	2	2	2	2	2	2	2	Pin	7/8"x3 3/4"
	204137	4	4	4	4	4	4	4	4	4	4	4	4	4	4	4	4	4	4	4	4	Cotter	3/8"x1 1/2"
41		8	8	8	8	8	8	8	8	8	8	8	8	8	8	8	8	8	8	8	8	Bolt w/Nut, Grade 5	7/8"x7 1/2"
	303958	8	8	8	8	8	8	8	8	8	8	8	8	8	8	8	8	8	8	8	8	Lock Washer	7/8"
42	203748	4	4	4	4	4	4	4	4	4	4	4	4	4	4	4	4	4	4	4	4	Shoulder Bolt	
	303958	4	4	4	4	4	4	4	4	4	4	4	4	4	4	4	4	4	4	4	4	Lock Washer	7/8"
43	208484	1	1	1	1	1	1	1	1	1	1	1	1	1	1	1	1	1	1	1	1	Depth Bar Bolt	1 1/8"x6 3/4"
	304039	1	1	1	1	1	1	1	1	1	1	1	1	1	1	1	1	1	1	1	1	Slotted Nut	1 1/4"
	304109	1	1	1	1	1	1	1	1	1	1	1	1	1	1	1	1	1	1	1	1	Cotter	3/16"x1 1/2"
44	208000	2	2	2	2	2	2	2	2	2	2	2	2	2	2	2	2	2	2	2	2	Tongue Hinge Pin	
		2	2	2	2	2	2	2	2	2	2	2	2	2	2	2	2	2	2	2	2	Bolt w/Nut	1/2"x2 3/8"
	303955	2	2	2	2	2	2	2	2	2	2	2	2	2	2	2	2	2	2	2	2	Lock Washer	1/2"
45	208862	2	2	2	2	2	2	2	2	2	2	2	2	2	2	2	2	2	2	2	2	Hydraulic Cylinder Bracket	
	208935	2	2	2	2	2	2	2	2	2	2	2	2	2	2	2	2	2	2	2	2	Tension Bushing	1 1/4"IDx1/4"W
46	209392	1	1	1	1	1	1	1	1	1	1	1	1	1	1	1	1	1	1	1	1	Wheel Lift	
47		8	8	8	8	8	8	8	8	8	8	8	8	8	8	8	8	8	8	8	8	Bolt w/Nut	3/4"x5 1/2"
	303957	8	8	8	8	8	8	8	8	8	8	8	8	8	8	8	8	8	8	8	8	Lock Washer	3/4"
48	208125	2	2	2	2	2	2	2	2	2	2	2	2	2	2	2	2	2	2	2	2	Front Gang Tube, 8-Disc	68 3/4"
49	208087	4	4	4	4	4	4	4	4	4	4	4	4	4	4	4	4	4	4	4	4	Pin, C.R.	1 1/8"x6 1/8"
	304151	8	8	8	8	8	8	8	8	8	8	8	8	8	8	8	8	8	8	8	8	Cotter	3/8"x2"
50	209378	2	2	2	2	2	2	2	2	2	2	2	2	2	2	2	2	2	2	2	2	Male Swivel	
	304194	2	2	2	2	2	2	2	2	2	2	2	2	2	2	2	2	2	2	2	2	Alemite (Straight)	3/8"
51	209387	2	2	2	2	2	2	2	2	2	2	2	2	2	2	2	2	2	2	2	2	Female Swivel	
	304194	2	2	2	2	2	2	2	2	2	2	2	2	2	2	2	2	2	2	2	2	Alemite (Straight)	3/8"
52	209394	1	1	1	0	0	0	0	0	1	0	0	0	0	1	0	0	0	0	0	0	Left Wing Wheel Lift	
	209396	0	0	0	1	1	1	1	1	0	0	1	1	1	0	0	1	1	1	1	1	Left Wing Wheel Lift	
53		16	16	16	16	16	16	16	16	16	16	16	16	16	16	16	16	16	16	16	16	Bolt w/Nut, Grade 5	7/8"x5 1/2"
	303958	16	16	16	16	16	16	16	16	16	16	16	16	16	16	16	16	16	16	16	16	Lock Washer	3/8"
54	209610	1	1	1	1	1	1	1	1	1	1	1	1	1	1	1	1	1	1	1	1	Center Frame	
	208935	2	2	2	2	2	2	2	2	2	2	2	2	2	2	2	2	2	2	2	2	Tension Bushing	1 1/4"IDx1/4"W

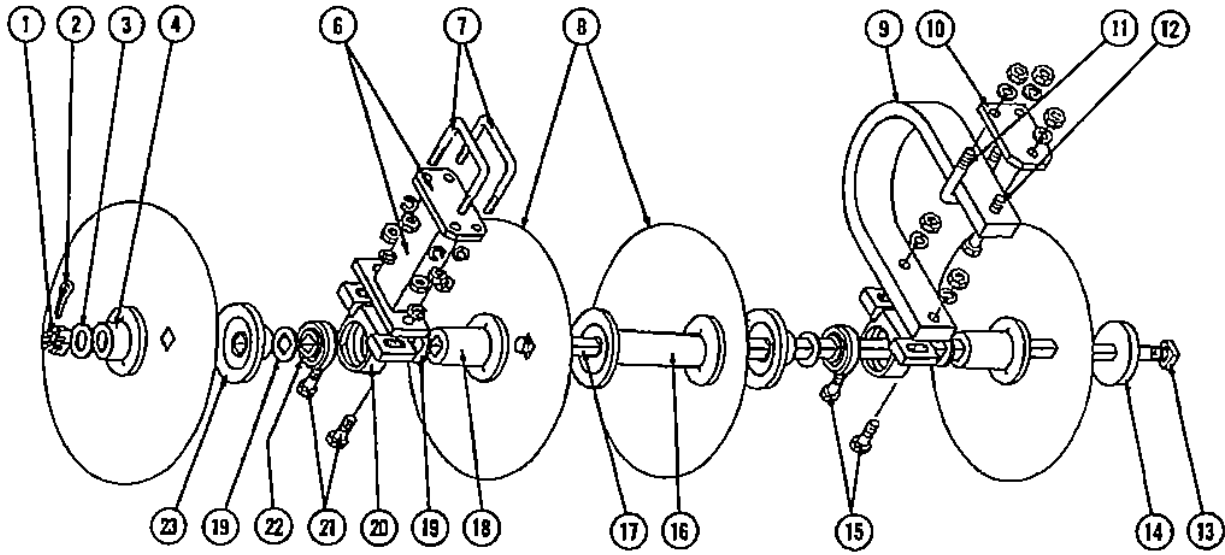
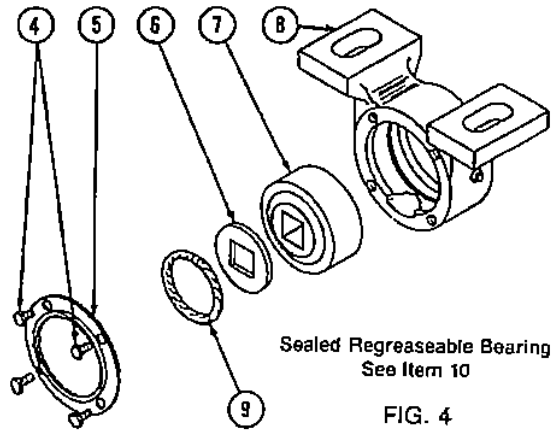
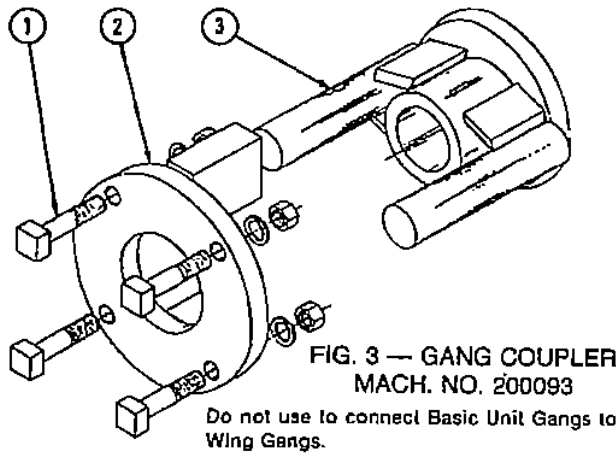

FIG. 2 — DISC GANG ASSEMBLY

Item No.	Part Number	FOR MODEL																Description	Size				
		200284	200285	200286	200287	200288	200289	200290	200291	200310	200311	200312	200313	200314	200315	200320	200321			200322	200323	200324	200325
1	304042	12	16	16	16	16	16	18	20	10	12	12	12	14	14	12	14	14	14	16	16	Hex Slotted Nut	1 1/2"
2	304142	12	16	16	16	16	16	18	20	10	12	12	12	14	14	12	14	14	14	16	16	Cotter	3/8"x3"
3	303979	12	16	16	16	16	16	18	20	10	12	12	12	14	14	12	14	14	14	16	16	Washer	1 1/2"
4	204438	12	16	16	16	16	16	18	20	10	12	12	12	14	14	12	14	14	14	16	16	End Washer	
5	206813	0	0	0	0	0	0	0	0	0	0	0	0	0	0	0	0	0	0	0	0	Offset Bearing Connector	
6	206682	24	32	32	32	32	32	36	40	20	24	24	24	28	28	24	28	28	28	32	32	Bearing Connector	
7	209612	48	64	64	64	64	64	72	80	40	48	48	48	56	56	48	56	56	56	64	64	U-Bolt w/Nuts	3/8"
																						Lock Washers	3/8"
<p>Note: One disc blade 2" smaller on front wing gangs at lead position. Two disc blades taper at 2" intervals on outside of rear wing gangs.</p>																							
8	208836	52	60	64	68	72	76	80	84	52	56	60	64	68	72	56	60	66	70	74	78	22" x 3/16" Cut-Out Disc	
	208837	52	60	64	68	72	76	80	84	52	56	60	64	68	72	56	60	66	70	74	78	22" x 3/16" Round Disc	
	207903	52	60	64	68	72	76	80	84	52	56	60	64	68	72	56	60	66	70	74	78	24" x 3/16" Cut-Out Disc	
	207904	52	60	64	68	72	76	80	84	52	56	60	64	68	72	56	60	66	70	74	78	24" x 3/16" Round Disc	
	207909	52	60	64	68	72	76	80	84	52	56	60	64	68	72	56	60	66	70	74	78	22" x 1/4" Cut-Out Disc	
	207910	52	60	64	68	72	76	80	84	52	56	60	64	68	72	56	60	66	70	74	78	22" x 1/4" Round Disc	
	207901	52	60	64	68	72	76	80	84	52	56	60	64	68	72	56	60	66	70	74	78	24" x 1/4" Cut-Out Disc	
	207902	52	60	64	68	72	76	80	84	52	56	60	64	68	72	56	60	66	70	74	78	24" x 1/4" Round Disc	
	209409	52	60	64	68	72	76	80	84	52	56	60	64	68	72	56	60	66	70	74	78	24" x 3/16" Cut-Out Disc	
	209410	52	60	64	68	72	76	80	84	52	56	60	64	68	72	56	60	66	70	74	78	24" x 3/16" Round Disc	
TAPERED DISC BLADES FOR WINGS WITH 22" DISC BLADES																							
	207911	4	4	4	4	4	4	4	4	4	4	4	4	4	4	4	4	4	4	4	4	20" x 1/4" Cut-Out Disc	
	207912	4	4	4	4	4	4	4	4	4	4	4	4	4	4	4	4	4	4	4	4	20" x 1/4" Round Disc	
	207913	2	2	2	2	2	2	2	2	2	2	2	2	2	2	2	2	2	2	2	2	18" x 1/4" Cut-Out Disc	
	207914	2	2	2	2	2	2	2	2	2	2	2	2	2	2	2	2	2	2	2	2	18" x 1/4" Round Disc	
TAPERED DISC BLADES FOR WINGS WITH 24" x 3/16" DISC BLADES																							
	208836	4	4	4	4	4	4	4	4	4	4	4	4	4	4	4	4	4	4	4	4	22" x 3/16" Cut-Out Disc	
	208837	4	4	4	4	4	4	4	4	4	4	4	4	4	4	4	4	4	4	4	4	22" x 3/16" Round Disc	
	207911	2	2	2	2	2	2	2	2	2	2	2	2	2	2	2	2	2	2	2	2	20" x 1/4" Cut-Out Disc	
	207912	2	2	2	2	2	2	2	2	2	2	2	2	2	2	2	2	2	2	2	2	20" x 1/4" Round Disc	
TAPERED DISC BLADES FOR WINGS WITH 24" x 1/4" & 24" x 5/16" DISC BLADES																							
	207909	4	4	4	4	4	4	4	4	4	4	4	4	4	4	4	4	4	4	4	4	22" x 1/4" Cut-Out Disc	
	207910	4	4	4	4	4	4	4	4	4	4	4	4	4	4	4	4	4	4	4	4	22" x 1/4" Round Disc	
	207911	2	2	2	2	2	2	2	2	2	2	2	2	2	2	2	2	2	2	2	2	20" x 1/4" Cut-Out Disc	
	207912	2	2	2	2	2	2	2	2	2	2	2	2	2	2	2	2	2	2	2	2	20" x 1/4" Round Disc	
9	207800	24	32	32	32	32	32	36	40	20	24	24	24	28	28	24	28	28	28	32	32	Spring Bearing Connector	
10	207837	24	32	32	32	32	32	36	40	20	24	24	24	28	28	24	28	28	28	32	32	Top Plate	
11	209500	24	32	32	32	32	32	36	40	20	24	24	24	28	28	24	28	28	28	32	32	U-Bolt w/Nuts	3/4"
	303957	48	64	64	64	64	64	72	80	40	48	48	48	56	56	48	56	56	56	64	64	Lock Washer	3/2"
12		24	32	32	32	32	32	36	40	20	24	24	24	28	28	24	28	28	28	32	32	Bolt w/Nut	3/8"x6 1/2"
	303974	24	32	32	32	32	32	36	40	20	24	24	24	28	28	24	28	28	28	32	32	Lock Washer	3/8"

Item No.	Part Number	FOR MODEL														Description	Size							
		200284	200285	200286	200287	200288	200289	200290	200291	200310	200311	200312	200313	200314	200315			200320	200321	200322	200323	200324	200325	
13	208930	12	16	16	16	16	16	18	20	10	12	12	12	14	14	12	14	14	14	16	16	Square Nut	1½"	
14	206765	12	16	16	16	16	16	18	20	10	12	12	12	14	14	12	14	14	14	16	16	Butt Plate		
15		48	64	64	64	64	64	72	80	40	48	48	48	56	56	48	56	56	64	64	64	Bolt w/Nut	¾"x2¾"	
	303974	48	64	64	64	64	64	72	80	40	48	48	48	56	56	48	56	56	64	64	64	Lock Washer	¾"	
16	207932	22	18	22	26	30	34	32	30	0	0	0	0	0	0	10	12	16	18	14	16	Double End Spacer 9" Spac.		
	207347	0	0	0	0	0	0	0	0	0	28	26	30	34	32	36	16	12	14	16	18	20	Double End Spacer 10½" Spac.	
17	208267	8	14	10	8	8	8	10	10	0	0	0	0	0	0	6	4	4	4	6	4	4-Disc Axle, 9" Spac.	33¼"	
	208178	0	2	6	6	4	2	4	10	0	0	0	0	0	0	2	4	2	0	4	6	5-Disc Axle, 9" Spac.	42¼"	
	208174	2	0	0	2	2	2	2	0	0	0	0	0	0	0	0	0	0	2	0	0	6-Disc Axle, 9" Spac.	51¼"	
	208175	2	0	0	0	2	4	2	0	0	0	0	0	0	0	0	0	2	2	0	0	7-Disc Axle, 9" Spac.	60¼"	
	207633	0	0	0	0	0	0	0	0	0	2	0	0	0	0	0	2	0	0	0	0	3-Disc Axle, 10½" Spac.	28"	
	207631	0	0	0	0	0	0	0	0	4	2	4	2	6	4	0	0	2	2	0	0	4-Disc Axle, 10½" Spac.	38¼"	
	207632	0	0	0	0	0	0	0	0	0	4	2	2	2	2	0	2	2	0	2	0	5-Disc Axle, 10½" Spac.	49"	
	207877	0	0	0	0	0	0	0	0	0	2	4	2	4	0	0	0	2	2	4	4	6-Disc Axle, 10½" Spac.	59½"	
	208393	0	0	0	0	0	0	0	0	6	4	4	4	4	4	2	2	2	2	2	2	7-Disc Axle, 10½" Spac.	70"	
18	207930	24	32	32	32	32	36	40	0	0	0	0	0	0	0	16	16	16	16	20	20	Convex Spacer, 9" Spac.		
	206631	0	0	0	0	0	0	0	0	20	24	24	24	28	28	8	12	12	12	12	12	Convex Spacer, 10½" Spac.		
19	204330	48	64	64	64	64	64	72	80	40	48	48	48	56	56	48	56	56	56	64	64	Special Flat Washer		
20	207020	24	32	32	32	32	36	40	20	24	24	24	24	28	28	24	28	28	28	32	32	Bearing Holder, Regreaseable		
	304194	24	32	32	32	32	36	40	20	24	24	24	24	28	28	24	28	28	28	32	32	Alemite (Straight)	¼"	
21		48	64	64	64	64	64	72	80	40	48	48	48	56	56	48	56	56	56	64	64	Bolt w/Nut	¾"x2½"	
	303958	48	64	64	64	64	64	72	80	40	48	48	48	56	56	48	56	56	56	64	64	Lock Washer	¾"	
22	207022	24	32	32	32	32	36	40	20	24	24	24	28	28	24	28	28	28	32	32	32	Ball Bearing, Regreaseable		
23	206630	24	32	32	32	32	36	40	0	0	0	0	0	0	0	16	16	16	16	20	20	Concave Spacer, 9" Spac.		
	204437	0	0	0	0	0	0	0	0	20	24	24	24	28	28	8	12	12	12	12	12	Concave Spacer, 10½" Spac.		



Item No.	Part Number	FOR MODEL														Description	Size						
		200284	200285	200286	200287	200288	200289	200290	200291	200310	200311	200312	200313	200314	200315			200320	200321	200322	200323	200324	200325
1	303906	16	32	32	32	32	32	40	48	8	16	16	16	24	24	16	24	24	24	32	32	Bolt Sq. Head	½"x2½"
	304007	16	32	32	32	32	32	40	48	8	16	16	16	24	24	16	24	24	24	32	32	Nut	½"
	303955	16	32	32	32	32	32	40	48	8	16	16	16	24	24	16	24	24	24	32	32	Lock Washer	½"
2	207323	4	8	8	8	8	8	10	12	2	4	4	4	6	6	4	6	6	6	8	8	Butt Plate Driver	
3	207318	4	8	8	8	8	8	10	12	2	4	4	4	6	6	4	6	6	6	8	8	End Washer Drive	
4	207862	192	256	256	256	256	288	320	160	192	192	192	224	224	192	224	224	224	256	256	256	Self Tapping Screw	#10x24-½"
5	207789	48	64	64	64	64	64	72	80	40	48	48	48	56	56	48	56	56	56	64	64	Seal Cap	
6	209171	48	64	64	64	64	64	72	80	40	48	48	48	56	56	48	56	56	56	64	64	Special Flat Washer	
7	207022	24	32	32	32	32	36	40	20	24	24	24	24	28	28	24	28	28	28	32	32	Ball Bearing, Regreaseable	
8	207020	24	32	32	32	32	36	40	20	24	24	24	24	28	28	24	28	28	28	32	32	Bearing Holder, Regreaseable	
	304194	24	32	32	32	32	36	40	20	24	24	24	24	28	28	24	28	28	28	32	32	Alemite (Straight)	¼"
9	207863	48	64	64	64	64	64	72	80	40	48	48	48	56	56	48	56	56	56	64	64	¼" Graphite Packing	
10	208550	24	32	32	32	32	36	40	20	24	24	24	28	28	24	28	28	28	28	32	32	Sealed Regreaseable Bearing (Complete)	
																						Includes Items 4 thru 9.	

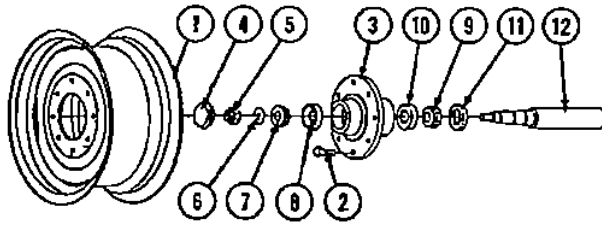

FIG. 5 — WHEEL HUB ASSEMBLY
WHEEL HUB (COMPLETE) SEE ITEM 13
WHEEL HUB (REPAIR KIT) SEE ITEM 14

Item No.	Part Number	FOR MODEL															Description	Size					
		200284	200285	200286	200287	200288	200289	200290	200291	200310	200311	200312	200313	200314	200315	200320			200321	200322	200323	200324	200325
1	209866	6	6	6	6	6	6	6	6	6	6	6	6	6	6	6	6	6	6	6	6	15" x 10" Flotation Rims	
2	209868	48	48	48	48	48	48	48	48	48	48	48	48	48	48	48	48	48	48	48	48	Lug Bolt	
3	209880	6	6	6	6	6	6	6	6	6	6	6	6	6	6	6	6	6	6	6	6	Wheel Hub	
4	209869	6	6	6	6	6	6	6	6	6	6	6	6	6	6	6	6	6	6	6	6	Hub Cap	
5	204522	6	6	6	6	6	6	6	6	6	6	6	6	6	6	6	6	6	6	6	6	Bearing Adjustment Nut	
6	304094	6	6	6	6	6	6	6	6	6	6	6	6	6	6	6	6	6	6	6	6	Cotter	1/2" x 1 1/4"
7	303974	6	6	6	6	6	6	6	6	6	6	6	6	6	6	6	6	6	6	6	6	Flat Washer	7/8"
8	209871	6	6	6	6	6	6	6	6	6	6	6	6	6	6	6	6	6	6	6	6	Bearing Cone	
9	209870	6	6	6	6	6	6	6	6	6	6	6	6	6	6	6	6	6	6	6	6	Bearing Cup	
10	209878	6	6	6	6	6	6	6	6	6	6	6	6	6	6	6	6	6	6	6	6	Bearing Cone	
11	209872	6	6	6	6	6	6	6	6	6	6	6	6	6	6	6	6	6	6	6	6	Bearing Cup	
12	209873	2	2	2	2	2	2	2	2	2	2	2	2	2	2	2	2	2	2	2	2	Grease Seal	
13	209874	2	2	2	2	2	2	2	2	2	2	2	2	2	2	2	2	2	2	2	2	Stub Axle (Assembly for Single Hub)	
14	209889	6	6	6	6	6	6	6	6	6	6	6	6	6	6	6	6	6	6	6	6	Stub Axle (Assembly for Double Hub)	
13	207889	6	6	6	6	6	6	6	6	6	6	6	6	6	6	6	6	6	6	6	6	Wheel Hub (Complete) Includes Items 2, 3, 4, 5, 6, 7, 8, 9, 10, & 11.	
14	207937	6	6	6	6	6	6	6	6	6	6	6	6	6	6	6	6	6	6	6	6	Wheel Hub Repair Kit. Includes Items 7, 8, 9, 10, & 11.	

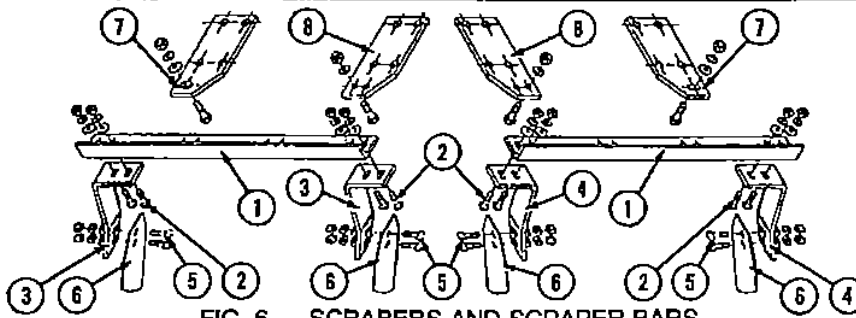

FIG. 6 — SCRAPERS AND SCRAPER BARS

Item No.	Part Number	FOR MODEL															Description	Size					
		200284	200285	200286	200287	200288	200289	200290	200291	200310	200311	200312	200313	200314	200315	200320			200321	200322	200323	200324	200325
1	209793	1	2	1	1	1	1	1	2	0	0	0	0	0	0	1	1	1	1	1	1	Right 3-Disc Scraper Bar, 9" Spacing	
1	209792	1	2	1	1	1	1	1	2	0	0	0	0	0	0	1	1	1	1	1	1	Left 3-Disc Scraper Bar, 9" Spacing	
2	209795	3	5	5	4	4	4	4	3	0	0	0	0	0	2	1	1	1	2	1	1	Right 4-Disc Scraper Bar, 9" Spacing	
2	209794	3	5	5	4	4	4	4	3	0	0	0	0	0	2	1	1	1	2	1	1	Left 4-Disc Scraper Bar, 9" Spacing	
3	209797	1	1	2	2	1	0	3	5	0	0	0	0	0	0	2	1	0	2	3	3	Right 5-Disc Scraper Bar, 9" Spacing	
3	209796	1	1	2	2	1	0	3	5	0	0	0	0	0	0	1	2	1	0	2	3	Left 5-Disc Scraper Bar, 9" Spacing	
4	209799	0	0	0	0	1	1	1	0	0	0	0	0	0	0	0	0	0	1	0	0	Right 6-Disc Scraper Bar, 9" Spacing	
4	209798	0	0	0	0	1	1	1	0	0	0	0	0	0	0	0	0	0	1	0	0	Left 6-Disc Scraper Bar, 9" Spacing	
5	209801	1	0	0	0	1	2	1	0	0	0	0	0	0	0	0	1	1	0	0	0	Right 7-Disc Scraper Bar, 9" Spacing	
5	209800	1	0	0	0	1	2	1	0	0	0	0	0	0	0	0	1	1	0	0	0	Left 7-Disc Scraper Bar, 9" Spacing	
6	209529	0	0	0	0	0	0	0	0	0	1	0	0	0	0	1	0	0	0	0	0	Right 2-Disc Scraper Bar, 10 1/2" Spacing	
6	209530	0	0	0	0	0	0	0	0	0	1	0	0	0	0	1	0	0	0	0	0	Left 2-Disc Scraper Bar, 10 1/2" Spacing	
7	209505	0	0	0	0	0	0	0	0	2	1	3	1	4	1	0	0	2	1	1	0	Right 4-Disc Scraper Bar, 10 1/2" Spacing	
7	209506	0	0	0	0	0	0	0	0	2	1	3	1	4	1	0	0	2	1	1	0	Left 4-Disc Scraper Bar, 10 1/2" Spacing	
7	209507	0	0	0	0	0	0	0	0	0	2	0	2	0	1	0	1	0	1	0	1	Right 5-Disc Scraper Bar, 10 1/2" Spacing	
7	209508	0	0	0	0	0	0	0	0	0	2	0	2	0	1	0	1	0	1	0	1	Left 5-Disc Scraper Bar, 10 1/2" Spacing	
7	209510	0	0	0	0	0	0	0	0	2	1	2	2	2	1	0	0	0	1	1	1	Right 6-Disc Scraper Bar, 10 1/2" Spacing	
7	209509	0	0	0	0	0	0	0	0	2	1	2	2	2	1	0	0	0	1	1	1	Left 6-Disc Scraper Bar, 10 1/2" Spacing	
2	108	124	132	140	148	156	164	172	98	116	124	132	140	148	116	124	136	144	152	160	160	Carriage Bolt w/Nut	1/2" x 1 1/2"
2	108	124	132	140	148	156	164	172	98	116	124	132	140	148	116	124	136	144	152	160	160	Flat Washer	1/2"
3	209888	27	31	33	35	37	39	41	43	27	29	31	33	35	37	29	31	34	36	38	40	Lock Washer	1/2"
4	209889	27	31	33	35	37	39	41	43	27	29	31	33	35	37	29	31	34	36	38	40	Right Scraper Handle	
5	108	124	132	140	148	156	164	172	98	116	124	132	140	148	116	124	136	144	152	160	160	Left Scraper Handle	
5	108	124	132	140	148	156	164	172	98	116	124	132	140	148	116	124	136	144	152	160	160	Carriage Bolt w/Nut	1/2" x 1 1/4"
5	108	124	132	140	148	156	164	172	98	116	124	132	140	148	116	124	136	144	152	160	160	Flat Washer	1/2"
5	108	124	132	140	148	156	164	172	98	116	124	132	140	148	116	124	136	144	152	160	160	Lock Washer	1/2"
6	209851	54	62	66	70	74	78	82	86	49	58	62	66	70	74	58	62	68	72	76	80	Scraper Blade	
7	209502	24	32	32	32	32	32	36	40	16	20	20	20	24	16	20	24	24	24	28	28	Scraper Bar Connector (Spring)	
7	209502	24	32	32	32	32	32	36	40	16	20	20	24	16	20	24	24	24	24	28	28	Bolt w/Nut	5/8" x 1 3/4"
7	209502	24	32	32	32	32	32	36	40	16	20	20	24	16	20	24	24	24	24	28	28	Flat Washer	5/8"
7	209502	24	32	32	32	32	32	36	40	16	20	20	24	16	20	24	24	24	24	28	28	Lock Washer	5/8"
8	209501	24	32	32	32	32	32	36	40	16	20	20	24	16	20	24	24	24	24	28	28	Scraper Bar Connector (Rigid)	
8	209501	24	32	32	32	32	32	36	40	16	20	20	24	16	20	24	24	24	24	28	28	Bolt w/Nut	5/8" x 1 3/4"
8	209501	24	32	32	32	32	32	36	40	16	20	20	24	16	20	24	24	24	24	28	28	Lock Washer	5/8"

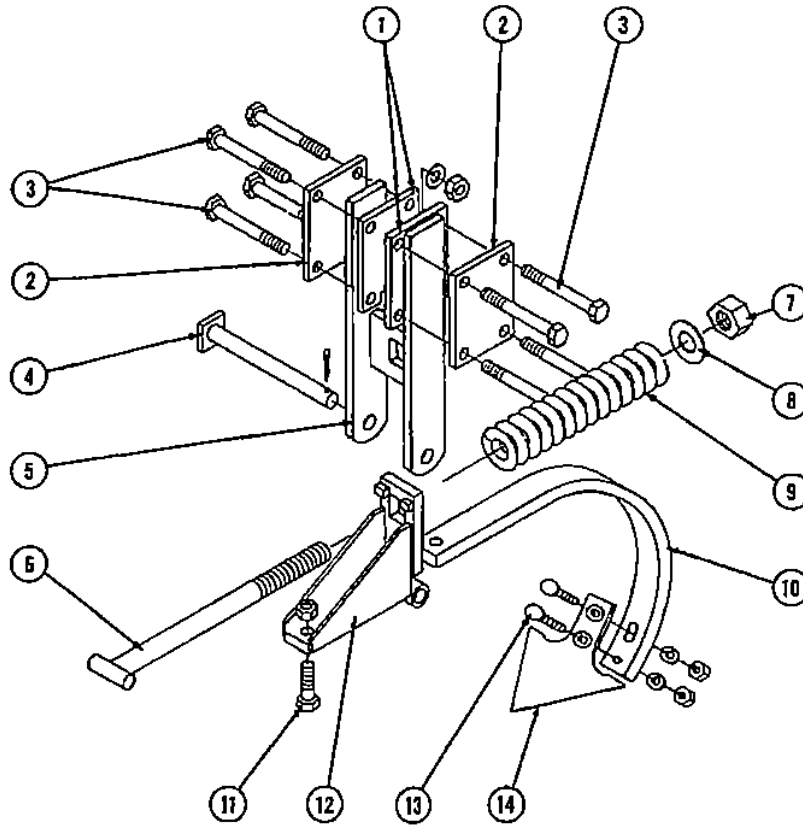

FIG. 7 — BALK BREAKER ATTACHMENT

Item No.	Part Number	FOR MODEL														Description	Size							
		200284	200285	200288	200287	200288	200289	200290	200291	200310	200311	200312	200313	200314	200315			200320	200321	200322	200323	200324	200325	
1	209472	2	2	2	2	2	2	2	2	2	2	2	2	2	2	2	2	2	2	2	2	2	Connector Plate (Inside)	
2	209471	2	2	2	2	2	2	2	2	2	2	2	2	2	2	2	2	2	2	2	2	2	Connector Plate (Outside)	
3	303394	8	8	8	8	8	8	8	8	8	8	8	8	8	8	8	8	8	8	8	8	8	Bolt	3/8" x 5 1/2"
	304008	8	8	8	8	8	8	8	8	8	8	8	8	8	8	8	8	8	8	8	8	8	Nut	3/8"
	303956	8	8	8	8	8	8	8	8	8	8	8	8	8	8	8	8	8	8	8	8	8	Lock Washer	3/8"
4	209850	1	1	1	1	1	1	1	1	1	1	1	1	1	1	1	1	1	1	1	1	1	Hinge Pin	
	304137	1	1	1	1	1	1	1	1	1	1	1	1	1	1	1	1	1	1	1	1	1	Cotter	
5	209463	1	1	1	1	1	1	1	1	1	1	1	1	1	1	1	1	1	1	1	1	1	Balk Breaker Slide	
6	209468	1	1	1	1	1	1	1	1	1	1	1	1	1	1	1	1	1	1	1	1	1	Spring Rod	
7	304026	1	1	1	1	1	1	1	1	1	1	1	1	1	1	1	1	1	1	1	1	1	Lock Nut	1 1/4"
8	303977	1	1	1	1	1	1	1	1	1	1	1	1	1	1	1	1	1	1	1	1	1	Flat Washer	1 1/4"
9	209148	1	1	1	1	1	1	1	1	1	1	1	1	1	1	1	1	1	1	1	1	1	Compression Spring	
10	206726	1	1	1	1	1	1	1	1	1	1	1	1	1	1	1	1	1	1	1	1	1	22" x 1" Shank	
11	303388	1	1	1	1	1	1	1	1	1	1	1	1	1	1	1	1	1	1	1	1	1	Bolt	3/8" x 2 3/4"
	304021	1	1	1	1	1	1	1	1	1	1	1	1	1	1	1	1	1	1	1	1	1	Lock Nut	3/8"
12	209456	1	1	1	1	1	1	1	1	1	1	1	1	1	1	1	1	1	1	1	1	1	Shank Hinge	
13	303899	2	2	2	2	2	2	2	2	2	2	2	2	2	2	2	2	2	2	2	2	2	Plow Bolt	7/16" x 2 1/2"
	304006	2	2	2	2	2	2	2	2	2	2	2	2	2	2	2	2	2	2	2	2	2	Nut	7/16"
	303970	2	2	2	2	2	2	2	2	2	2	2	2	2	2	2	2	2	2	2	2	2	Flat Washer	7/16"
		2	2	2	2	2	2	2	2	2	2	2	2	2	2	2	2	2	2	2	2	2	Lock Washer	7/16"
14	209408	1	1	1	1	1	1	1	1	1	1	1	1	1	1	1	1	1	1	1	1	1	Sweep	

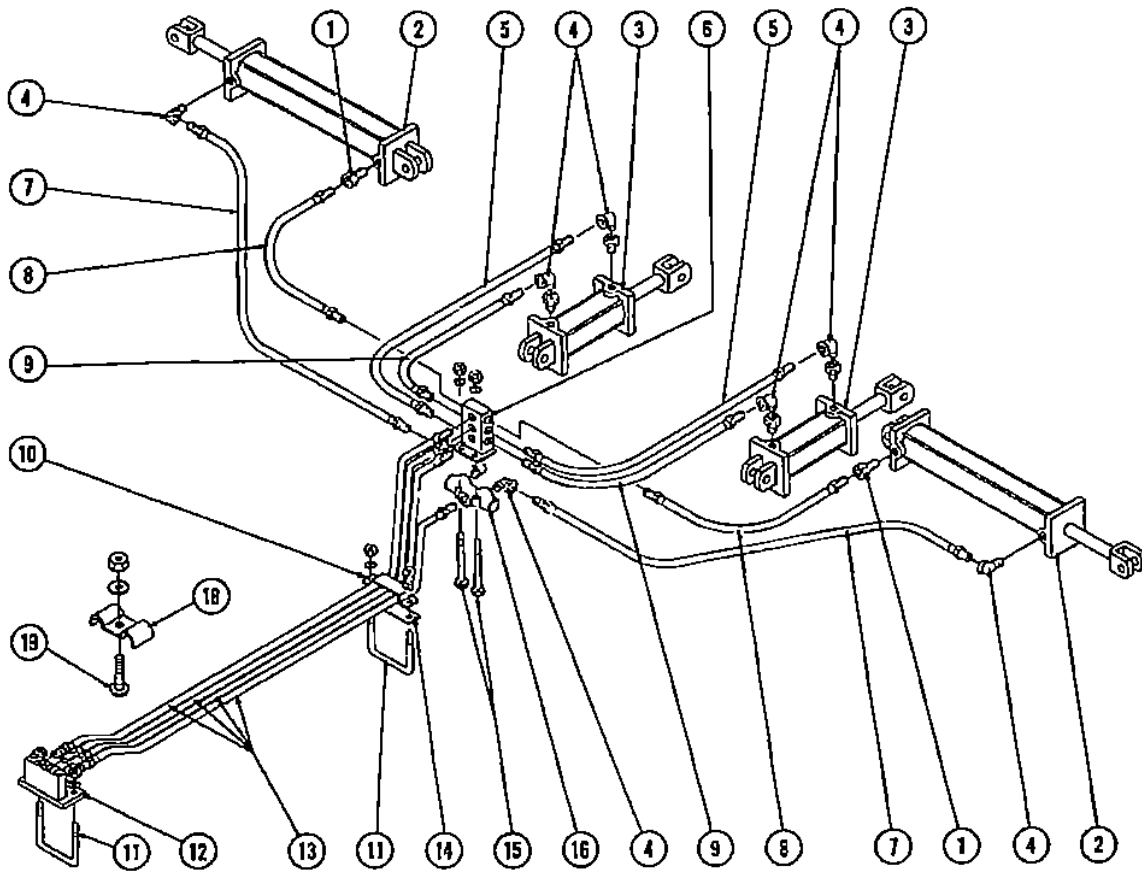

FIG. 8 — HYDRAULIC ASSEMBLY

Item No.	Part Number	FOR MODEL															Description	Size						
		200284	200285	200286	200287	200289	200289	200290	200291	200310	200311	200312	200313	200314	200315	200320			200321	200322	200323	200324	200325	
1	208569	2	2	2	2	2	2	2	2	2	2	2	2	2	2	2	2	2	2	2	2	2	Flow Restrictor	
2	207987	2	2	2	2	2	2	2	2	2	2	2	2	2	2	2	2	2	2	2	2	2	Hydraulic Cylinder	4"x24"
3	209368	2	2	2	2	2	2	2	2	2	2	2	2	2	2	2	2	2	2	2	2	2	Hydraulic Cylinder	5"x8"
4	207982	8	8	8	8	8	8	8	8	8	8	8	8	8	8	8	8	8	8	8	8	8	Street Elbow	
5	207976	2	2	2	2	2	2	2	2	2	2	2	2	2	2	2	2	2	2	2	2	2	Hydraulic Hose	1/2"x60"
6	209240	1	1	1	1	1	1	1	1	1	1	1	1	1	1	1	1	1	1	1	1	1	Manifold	
7	209243	2	2	2	2	2	2	2	2	2	2	2	2	2	2	2	2	2	2	2	2	2	Hydraulic Hose	1/2"x135"
8	207980	2	2	2	2	2	2	2	2	2	2	2	2	2	2	2	2	2	2	2	2	2	Hydraulic Hose	1/2"x105"
9	209226	2	2	2	2	2	2	2	2	2	2	2	2	2	2	2	2	2	2	2	2	2	Hydraulic Hose	1/2"x45"
10	209173	1	1	1	1	1	1	1	1	1	1	1	1	1	1	1	1	1	1	1	1	1	Hose Holder	
11	209239	2	2	2	2	2	2	2	2	2	2	2	2	2	2	2	2	2	2	2	2	2	U-Bolt w/Nuts	3/8"
	303972	4	4	4	4	4	4	4	4	4	4	4	4	4	4	4	4	4	4	4	4	4	Flat Washer	5/8"
	303956	4	4	4	4	4	4	4	4	4	4	4	4	4	4	4	4	4	4	4	4	4	Lock Washer	3/8"
12	209179	1	1	1	1	1	1	1	1	1	1	1	1	1	1	1	1	1	1	1	1	1	Header	
13	207980	4	4	4	4	4	4	4	4	4	4	4	4	4	4	4	4	4	4	4	4	4	Hydraulic Hose	1/2"x105"
14	209611	1	1	1	1	1	1	1	1	1	1	1	1	1	1	1	1	1	1	1	1	1	Hose Holder Base	
15		2	2	2	2	2	2	2	2	2	2	2	2	2	2	2	2	2	2	2	2	2	Bolt w/Nut	5/16"x3 1/2"
	303952	2	2	2	2	2	2	2	2	2	2	2	2	2	2	2	2	2	2	2	2	2	Lock Washer	5/16"
16	207984	1	1	1	1	1	1	1	1	1	1	1	1	1	1	1	1	1	1	1	1	1	Flow Divider	
	207985	1	1	1	1	1	1	1	1	1	1	1	1	1	1	1	1	1	1	1	1	1	Adapter	1" to 1/2"
	207986	2	2	2	2	2	2	2	2	2	2	2	2	2	2	2	2	2	2	2	2	2	Adapter	3/4" to 1/2"
17	207986	4	4	4	4	4	4	4	4	4	4	4	4	4	4	4	4	4	4	4	4	4	Adapter	3/4" to 1/2"
18	208259	8	8	8	8	8	8	8	8	8	8	8	8	8	8	8	8	8	8	8	8	8	Hose Clamp	
19		8	8	8	8	8	8	8	8	8	8	8	8	8	8	8	8	8	8	8	8	8	Carriage Bolt w/Nut	1/2"x1 3/4"
		8	8	8	8	8	8	8	8	8	8	8	8	8	8	8	8	8	8	8	8	8	Lock Washer	1/2"

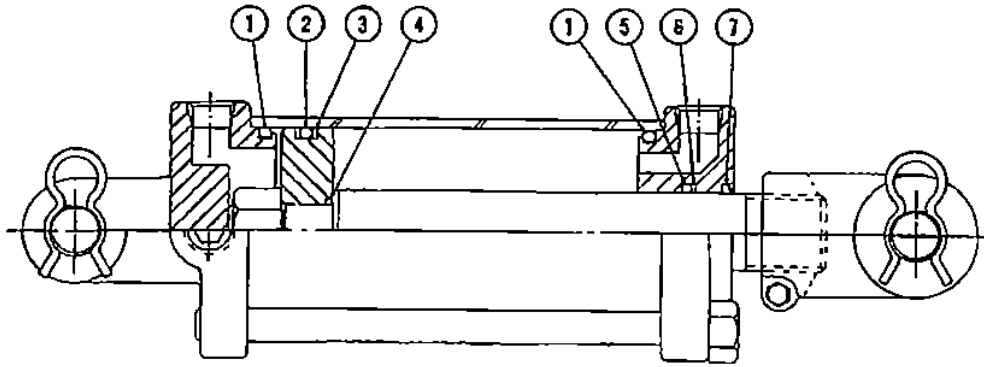

FIG. 9 — 4"×24" HYDRAULIC CYLINDER
SEAL KIT COMPLETE, SEE ITEM 8
CYLINDER COMPLETE, SEE ITEM 9

Item No.	Part Number	FOR MODEL																Description	Size					
		200284	200285	200286	200287	200288	200289	200290	200291	200310	200311	200312	200313	200314	200315	200320	200321			200322	200323	200324	200325	
1	208852	4	4	4	4	4	4	4	4	4	4	4	4	4	4	4	4	4	4	4	4	4	O-Ring	4"×24"
2	208853	2	2	2	2	2	2	2	2	2	2	2	2	2	2	2	2	2	2	2	2	2	O-Ring	4"×24"
3	208854	4	4	4	4	4	4	4	4	4	4	4	4	4	4	4	4	4	4	4	4	4	B/U Washer	4"×24"
4	208855	2	2	2	2	2	2	2	2	2	2	2	2	2	2	2	2	2	2	2	2	2	O-Ring	4"×24"
5	208856	2	2	2	2	2	2	2	2	2	2	2	2	2	2	2	2	2	2	2	2	2	O-Ring	4"×24"
6	208857	2	2	2	2	2	2	2	2	2	2	2	2	2	2	2	2	2	2	2	2	2	B/U Washer	4"×24"
7	208858	2	2	2	2	2	2	2	2	2	2	2	2	2	2	2	2	2	2	2	2	2	Wiper	4"×24"
8	208860	2	2	2	2	2	2	2	2	2	2	2	2	2	2	2	2	2	2	2	2	2	Seal Kit (Complete). Includes Items 1 thru 7.	4"×24"
9	207987	2	2	2	2	2	2	2	2	2	2	2	2	2	2	2	2	2	2	2	2	2	Hydraulic Cylinder	4"×24"

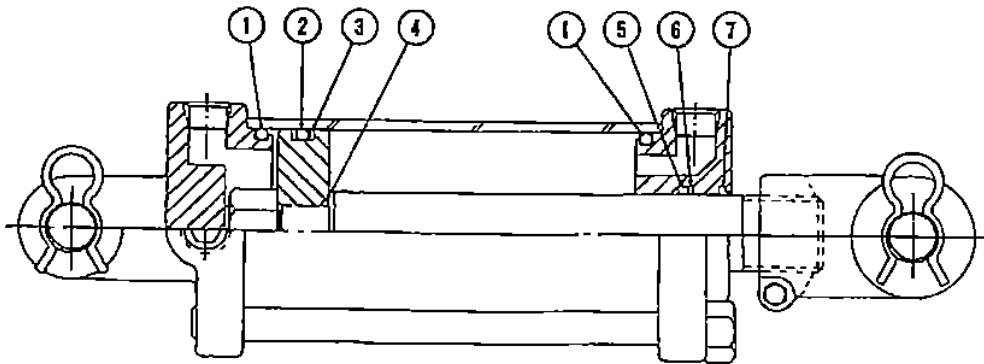

FIG. 10 — 5"×8" HYDRAULIC CYLINDER
SEAL KIT COMPLETE, SEE ITEM 8

Item No.	Part Number	FOR MODEL																Description	Size					
		200284	200285	200286	200287	200288	200289	200290	200291	200310	200311	200312	200313	200314	200315	200320	200321			200322	200323	200324	200325	
1	209828	4	4	4	4	4	4	4	4	4	4	4	4	4	4	4	4	4	4	4	4	4	O-Ring	5"×8"
2	209829	2	2	2	2	2	2	2	2	2	2	2	2	2	2	2	2	2	2	2	2	2	O-Ring	5"×8"
3	209830	4	4	4	4	4	4	4	4	4	4	4	4	4	4	4	4	4	4	4	4	4	B/U Washer	5"×8"
4	209831	2	2	2	2	2	2	2	2	2	2	2	2	2	2	2	2	2	2	2	2	2	O-Ring	5"×8"
5	209832	2	2	2	2	2	2	2	2	2	2	2	2	2	2	2	2	2	2	2	2	2	O-Ring	5"×8"
6	209833	2	2	2	2	2	2	2	2	2	2	2	2	2	2	2	2	2	2	2	2	2	B/U Washer	5"×8"
7	209834	2	2	2	2	2	2	2	2	2	2	2	2	2	2	2	2	2	2	2	2	2	Wiper	5"×8"
8	209846	2	2	2	2	2	2	2	2	2	2	2	2	2	2	2	2	2	2	2	2	2	Seal Kit (Complete). Includes Items 1 thru 7.	5"×8"
9	209368	2	2	2	2	2	2	2	2	2	2	2	2	2	2	2	2	2	2	2	2	2	Hydraulic Cylinder	5"×8"

PACKING LIST FOR HARROWS EQUIPPED WITH RIGID HANGERS

BUNDLE NUMBER	UNITS	MODEL NUMBERS												BOLES. SHPD.	DESCRIPTION						
		20284	20285	20286	20287	20288	20289	20291	200310	200311	200312	200313	200314			200315	200320	200321	200322	200323	200324
201982	1	1																		1	Tongue Bundle w/Dbl. Drawbar Clevis
201883	1	1																		1	Center Frame Bundle
201970	1	1																		1	Right Main Frame Bundle
201971	1	1																		1	Left Main Frame Bundle
202041	1	1																		1	Main Frame Wheel Axle
201972	1	1																		1	Small Right Wing Frame
201973	1	1																		1	Small Left Wing Frame
201974	1	1																		1	Large Right Wing Frame
201975	1	1																		1	Large Left Wing Frame
202043	1	1																		1	Small Right Wing Wheel Axle
202044	1	1																		1	Small Left Wing Wheel Axle
202045	1	1																		1	Large Right Wing Wheel Axle
202046	1	1																		1	Large Left Wing Wheel Axle
201276	2	2	2	2	2	2	2	2	2	2	2	2	2	2	2	2	2	2	2	2	Hydraulic Folding Arm Bundle
201957	1	1	1	1	1	1	1	1	1	1	1	1	1	1	1	1	1	1	1	1	Hydraulic Folding Arm Bundle
201956	2	2	2	2	2	2	2	2	2	2	2	2	2	2	2	2	2	2	2	2	3' x 8' Hydraulic Cylinder
201279	2	2	2	2	2	2	2	2	2	2	2	2	2	2	2	2	2	2	2	2	4' x 24" Hydraulic Cylinder w/Flow Restrictor
201278	1	1	1	1	1	1	1	1	1	1	1	1	1	1	1	1	1	1	1	1	Hydraulic Hose Bundle
202046	6	6	6	6	6	6	6	6	6	6	6	6	6	6	6	6	6	6	6	6	15' x 10' Rims
201320	1	1	1	1	1	1	1	1	1	1	1	1	1	1	1	1	1	1	1	1	Wing Stop Bundle
201555	1	1	1	1	1	1	1	1	1	1	1	1	1	1	1	1	1	1	1	1	Tongue Jack
201983	1	1	1	1	1	1	1	1	1	1	1	1	1	1	1	1	1	1	1	1	Right Front 8-Disc Gang (9" Spacing, Rigid Hanger)
201984	1	1	1	1	1	1	1	1	1	1	1	1	1	1	1	1	1	1	1	1	Left Front 8-Disc Gang (9" Spacing, Rigid Hanger)
201985	1	1	1	1	1	1	1	1	1	1	1	1	1	1	1	1	1	1	1	1	Right Rear 8-Disc Gang (9" Spacing, Rigid Hanger)
201986	1	1	1	1	1	1	1	1	1	1	1	1	1	1	1	1	1	1	1	1	Left Rear 8-Disc Gang (9" Spacing, Rigid Hanger)
201987	1	1	1	1	1	1	1	1	1	1	1	1	1	1	1	1	1	1	1	1	Right Front 6-Disc Wing Gang (9" Spacing, Rigid Hanger)
201988	1	1	1	1	1	1	1	1	1	1	1	1	1	1	1	1	1	1	1	1	Left Front 6-Disc Wing Gang (9" Spacing, Rigid Hanger)
201989	1	1	1	1	1	1	1	1	1	1	1	1	1	1	1	1	1	1	1	1	Right Rear 7-Disc Wing Gang (9" Spacing, Rigid Hanger)
201990	1	1	1	1	1	1	1	1	1	1	1	1	1	1	1	1	1	1	1	1	Left Rear 7-Disc Wing Gang (9" Spacing, Rigid Hanger)
201991	1	1	1	1	1	1	1	1	1	1	1	1	1	1	1	1	1	1	1	1	Right Front 8-Disc Wing Gang (9" Spacing, Rigid Hanger)
201992	1	1	1	1	1	1	1	1	1	1	1	1	1	1	1	1	1	1	1	1	Left Front 8-Disc Wing Gang (9" Spacing, Rigid Hanger)
201993	1	1	1	1	1	1	1	1	1	1	1	1	1	1	1	1	1	1	1	1	Right Rear 9-Disc Wing Gang (9" Spacing, Rigid Hanger)
201994	1	1	1	1	1	1	1	1	1	1	1	1	1	1	1	1	1	1	1	1	Left Rear 9-Disc Wing Gang (9" Spacing, Rigid Hanger)
201995	1	1	1	1	1	1	1	1	1	1	1	1	1	1	1	1	1	1	1	1	Right Front 9-Disc Wing Gang (9" Spacing, Rigid Hanger)
201996	1	1	1	1	1	1	1	1	1	1	1	1	1	1	1	1	1	1	1	1	Left Front 9-Disc Wing Gang (9" Spacing, Rigid Hanger)
201997	1	1	1	1	1	1	1	1	1	1	1	1	1	1	1	1	1	1	1	1	Right Rear 10-Disc Wing Gang (9" Spacing, Rigid Hanger)
201998	1	1	1	1	1	1	1	1	1	1	1	1	1	1	1	1	1	1	1	1	Left Rear 10-Disc Wing Gang (9" Spacing, Rigid Hanger)
201999	1	1	1	1	1	1	1	1	1	1	1	1	1	1	1	1	1	1	1	1	Right Front 10-Disc Wing Gang (9" Spacing, Rigid Hanger)
202000	1	1	1	1	1	1	1	1	1	1	1	1	1	1	1	1	1	1	1	1	Left Front 10-Disc Wing Gang (9" Spacing, Rigid Hanger)
202001	1	1	1	1	1	1	1	1	1	1	1	1	1	1	1	1	1	1	1	1	Right Rear 11-Disc Wing Gang (9" Spacing, Rigid Hanger)
202002	1	1	1	1	1	1	1	1	1	1	1	1	1	1	1	1	1	1	1	1	Left Rear 11-Disc Wing Gang (9" Spacing, Rigid Hanger)
202003	1	1	1	1	1	1	1	1	1	1	1	1	1	1	1	1	1	1	1	1	Right Front 11-Disc Wing Gang (9" Spacing, Rigid Hanger)
202004	1	1	1	1	1	1	1	1	1	1	1	1	1	1	1	1	1	1	1	1	Left Front 11-Disc Wing Gang (9" Spacing, Rigid Hanger)
202005	1	1	1	1	1	1	1	1	1	1	1	1	1	1	1	1	1	1	1	1	Right Rear 12-Disc Wing Gang (9" Spacing, Rigid Hanger)
202006	1	1	1	1	1	1	1	1	1	1	1	1	1	1	1	1	1	1	1	1	Left Rear 12-Disc Wing Gang (9" Spacing, Rigid Hanger)

PACKING LIST FOR HARROWS EQUIPPED WITH SPRING HANGERS

UNITS	MODEL NUMBERS															BDLES. SHPD.	DESCRIPTION					
	200284	200285	200286	200287	200288	200289	200290	200291	200310	200311	200312	200313	200314	200315	200320			200321	200322	200323	200324	200325
201982	1	1	1	1	1	1	1	1	1	1	1	1	1	1	1	1	1	1	1	1	1	Tongue Bundle w/Dbi. Drawbar Clevis
201883	1	1	1	1	1	1	1	1	1	1	1	1	1	1	1	1	1	1	1	1	1	Center Frame Bundle
201970	1	1	1	1	1	1	1	1	1	1	1	1	1	1	1	1	1	1	1	1	1	Right Main Frame Bundle
201971	1	1	1	1	1	1	1	1	1	1	1	1	1	1	1	1	1	1	1	1	1	Left Main Frame Bundle
202041	1	1	1	1	1	1	1	1	1	1	1	1	1	1	1	1	1	1	1	1	1	Main Frame Wheel Axle
201972	1	1	1	1	1	1	1	1	1	1	1	1	1	1	1	1	1	1	1	1	1	Small Right Wing Frame
201973	1	1	1	1	1	1	1	1	1	1	1	1	1	1	1	1	1	1	1	1	1	Small Left Wing Frame
201974	1	1	1	1	1	1	1	1	1	1	1	1	1	1	1	1	1	1	1	1	1	Large Right Wing Frame
201975	1	1	1	1	1	1	1	1	1	1	1	1	1	1	1	1	1	1	1	1	1	Large Left Wing Frame
202042	1	1	1	1	1	1	1	1	1	1	1	1	1	1	1	1	1	1	1	1	1	Small Right Wing Wheel Axle
202043	1	1	1	1	1	1	1	1	1	1	1	1	1	1	1	1	1	1	1	1	1	Small Left Wing Wheel Axle
202044	1	1	1	1	1	1	1	1	1	1	1	1	1	1	1	1	1	1	1	1	1	Large Right Wing Wheel Axle
202045	1	1	1	1	1	1	1	1	1	1	1	1	1	1	1	1	1	1	1	1	1	Large Left Wing Wheel Axle
201479	2	2	2	2	2	2	2	2	2	2	2	2	2	2	2	2	2	2	2	2	2	Hydraulic Folding Arm Bundle
201276	1	1	1	1	1	1	1	1	1	1	1	1	1	1	1	1	1	1	1	1	1	Hydraulic Folding Arm Bundle
201957	1	1	1	1	1	1	1	1	1	1	1	1	1	1	1	1	1	1	1	1	1	Bulk Breaker Bundle
201956	2	2	2	2	2	2	2	2	2	2	2	2	2	2	2	2	2	2	2	2	2	5" x 8" Hydraulic Cylinder
201279	2	2	2	2	2	2	2	2	2	2	2	2	2	2	2	2	2	2	2	2	2	4" x 24" Hydraulic Cylinder w/Flow Restrictor
201278	1	1	1	1	1	1	1	1	1	1	1	1	1	1	1	1	1	1	1	1	1	Hydraulic Hose Bundle
202046	6	6	6	6	6	6	6	6	6	6	6	6	6	6	6	6	6	6	6	6	6	15" x 10" Rims
201320	1	1	1	1	1	1	1	1	1	1	1	1	1	1	1	1	1	1	1	1	1	Wing Stop Bundle
201555	1	1	1	1	1	1	1	1	1	1	1	1	1	1	1	1	1	1	1	1	1	Tongue Jack
201920	1	1	1	1	1	1	1	1	1	1	1	1	1	1	1	1	1	1	1	1	1	Right Front 8-Disc Gang (9" Spacing, Spring Hanger)
201921	1	1	1	1	1	1	1	1	1	1	1	1	1	1	1	1	1	1	1	1	1	Left Front 8-Disc Gang (9" Spacing, Spring Hanger)
201922	1	1	1	1	1	1	1	1	1	1	1	1	1	1	1	1	1	1	1	1	1	Right Rear 8-Disc Gang (9" Spacing, Spring Hanger)
201923	1	1	1	1	1	1	1	1	1	1	1	1	1	1	1	1	1	1	1	1	1	Left Rear 8-Disc Gang (9" Spacing, Spring Hanger)
201924	1	1	1	1	1	1	1	1	1	1	1	1	1	1	1	1	1	1	1	1	1	Right Front 6-Disc Wing Gang (9" Spacing, Spring Hanger)
201925	1	1	1	1	1	1	1	1	1	1	1	1	1	1	1	1	1	1	1	1	1	Left Front 6-Disc Wing Gang (9" Spacing, Spring Hanger)
201926	1	1	1	1	1	1	1	1	1	1	1	1	1	1	1	1	1	1	1	1	1	Right Rear 7-Disc Wing Gang (9" Spacing, Spring Hanger)
201927	1	1	1	1	1	1	1	1	1	1	1	1	1	1	1	1	1	1	1	1	1	Left Rear 7-Disc Wing Gang (9" Spacing, Spring Hanger)
201928	1	1	1	1	1	1	1	1	1	1	1	1	1	1	1	1	1	1	1	1	1	Right Front 8-Disc Wing Gang (9" Spacing, Spring Hanger)
201929	1	1	1	1	1	1	1	1	1	1	1	1	1	1	1	1	1	1	1	1	1	Left Front 8-Disc Wing Gang (9" Spacing, Spring Hanger)
201930	1	1	1	1	1	1	1	1	1	1	1	1	1	1	1	1	1	1	1	1	1	Right Rear 9-Disc Wing Gang (9" Spacing, Spring Hanger)
201931	1	1	1	1	1	1	1	1	1	1	1	1	1	1	1	1	1	1	1	1	1	Left Rear 9-Disc Wing Gang (9" Spacing, Spring Hanger)
201932	1	1	1	1	1	1	1	1	1	1	1	1	1	1	1	1	1	1	1	1	1	Right Front 10-Disc Wing Gang (9" Spacing, Spring Hanger)
201933	1	1	1	1	1	1	1	1	1	1	1	1	1	1	1	1	1	1	1	1	1	Left Front 10-Disc Wing Gang (9" Spacing, Spring Hanger)
201934	1	1	1	1	1	1	1	1	1	1	1	1	1	1	1	1	1	1	1	1	1	Right Rear 10-Disc Wing Gang (9" Spacing, Spring Hanger)
201935	1	1	1	1	1	1	1	1	1	1	1	1	1	1	1	1	1	1	1	1	1	Left Rear 10-Disc Wing Gang (9" Spacing, Spring Hanger)
201936	1	1	1	1	1	1	1	1	1	1	1	1	1	1	1	1	1	1	1	1	1	Right Front 11-Disc Wing Gang (9" Spacing, Spring Hanger)
201937	1	1	1	1	1	1	1	1	1	1	1	1	1	1	1	1	1	1	1	1	1	Left Front 11-Disc Wing Gang (9" Spacing, Spring Hanger)
201938	1	1	1	1	1	1	1	1	1	1	1	1	1	1	1	1	1	1	1	1	1	Right Rear 11-Disc Wing Gang (9" Spacing, Spring Hanger)
201939	1	1	1	1	1	1	1	1	1	1	1	1	1	1	1	1	1	1	1	1	1	Left Rear 11-Disc Wing Gang (9" Spacing, Spring Hanger)
201940	1	1	1	1	1	1	1	1	1	1	1	1	1	1	1	1	1	1	1	1	1	Right Front 12-Disc Wing Gang (9" Spacing, Spring Hanger)
201941	1	1	1	1	1	1	1	1	1	1	1	1	1	1	1	1	1	1	1	1	1	Left Front 12-Disc Wing Gang (9" Spacing, Spring Hanger)
201942	1	1	1	1	1	1	1	1	1	1	1	1	1	1	1	1	1	1	1	1	1	Right Rear 12-Disc Wing Gang (9" Spacing, Spring Hanger)
201943	1	1	1	1	1	1	1	1	1	1	1	1	1	1	1	1	1	1	1	1	1	Left Rear 12-Disc Wing Gang (9" Spacing, Spring Hanger)

CENTER FRAME DISC GANG BUNDLES
MODELS 200284 — 200291

MODEL NO.	BUNDLE NUMBERS FOR RIGID BEARING CONNECTOR	BUNDLE NUMBERS FOR SPRING BEARING CONNECTOR
200284-291	Right Front, 8-Disc, 201983	Right Front, 8-Disc, 201920
200284-291	Left Front, 8-Disc, 201984	Left Front, 8-Disc, 201921
200284-291	Right Rear, 8-Disc, 201985	Right Rear, 8-Disc, 201922
200284-291	Left Rear, 8-Disc, 201986	Left Rear, 8-Disc, 201923

SMALL WING DISC GANG BUNDLES
MODELS 200284 — 200286

MODEL NO.	BUNDLE NUMBERS FOR RIGID BEARING CONNECTOR	BUNDLE NUMBERS FOR SPRING BEARING CONNECTOR
200284	Right Front, 6-Disc, 201924	
200284	Left Front, 6-Disc, 201925	
200284	Right Rear, 7-Disc, 201926	
200284	Left Rear, 7-Disc, 201927	
200284		Right Front, 6-Disc, 201987
200284		Left Front, 6-Disc, 201988
200284		Right Rear, 7-Disc, 201989
200284		Left Rear, 7-Disc, 201990
200285	Right Front, 8-Disc, 201928	
200285	Left Front, 8-Disc, 201929	
200285	Right Rear, 9-Disc, 201930	
200285	Left Rear, 9-Disc, 201931	
200285		Right Front, 8-Disc, 201991
200285		Left Front, 8-Disc, 201992
200285		Right Rear, 9-Disc, 201993
200285		Left Rear, 9-Disc, 201994
200286	Right Front, 9-Disc, 201932	
200286	Left Front, 9-Disc, 201933	
200286	Right Rear, 10-Disc, 201934	
200286	Left Rear, 10-Disc, 201935	
200286		Right Front, 9-Disc, 201995
200286		Left Front, 9-Disc, 201996
200286		Right Rear, 10-Disc, 201997
200286		Left Rear, 10-Disc, 201998

LARGE WING DISC GANG BUNDLES
MODELS 200287 — 200291

MODEL NO.	BUNDLE NUMBERS FOR RIGID BEARING CONNECTOR	BUNDLE NUMBERS FOR SPRING BEARING CONNECTOR
200287	Right Front, 10-Disc, 201999	
200287	Left Front, 10-Disc, 202000	
200287	Right Rear, 11-Disc, 202001	
200287	Left Rear, 11-Disc, 202002	
200287		Right Front, 10-Disc, 201936
200287		Left Front, 10-Disc, 201937
200287		Right Rear, 11-Disc, 201938
200287		Left Rear, 11-Disc, 201939
200288	Right Front, 11-Disc, 202003	
200288	Left Front, 11-Disc, 202004	
200288	Right Rear, 12-Disc, 202005	
200288	Left Rear, 12-Disc, 202006	
200288		Right Front, 11-Disc, 201940
200288		Left Front, 11-Disc, 201941
200288		Right Rear, 12-Disc, 201942
200288		Left Rear, 12-Disc, 201943
200289	Right Front, 12-Disc, 202007	
200289	Left Front, 12-Disc, 202008	
200289	Right Rear, 13-Disc, 202009	
200289	Left Rear, 13-Disc, 202010	
200289		Right Front, 12-Disc, 201944
200289		Left Front, 12-Disc, 201945
200289		Right Rear, 13-Disc, 201946
200289		Left Rear, 13-Disc, 201947
200290	Right Front, 13-Disc, 202011	
200290	Left Front, 13-Disc, 202012	
200290	Right Rear, 14-Disc, 202013	
200290	Left Rear, 14-Disc, 202014	
200290		Right Front, 13-Disc, 201948
200290		Left Front, 13-Disc, 201949
200290		Right Rear, 14-Disc, 201950
200290		Left Rear, 14-Disc, 201951
200291	Right Front, 14-Disc, 202015	
200291	Left Front, 14-Disc, 202016	
200291	Right Rear 15-Disc, 202017	
200291	Left Rear 15-Disc, 202018	
200291		Right Front, 14-Disc, 201952
200291		Left Front, 14-Disc, 201953
200291		Right Rear, 15-Disc, 201954
200291		Left Rear, 15-Disc, 201955

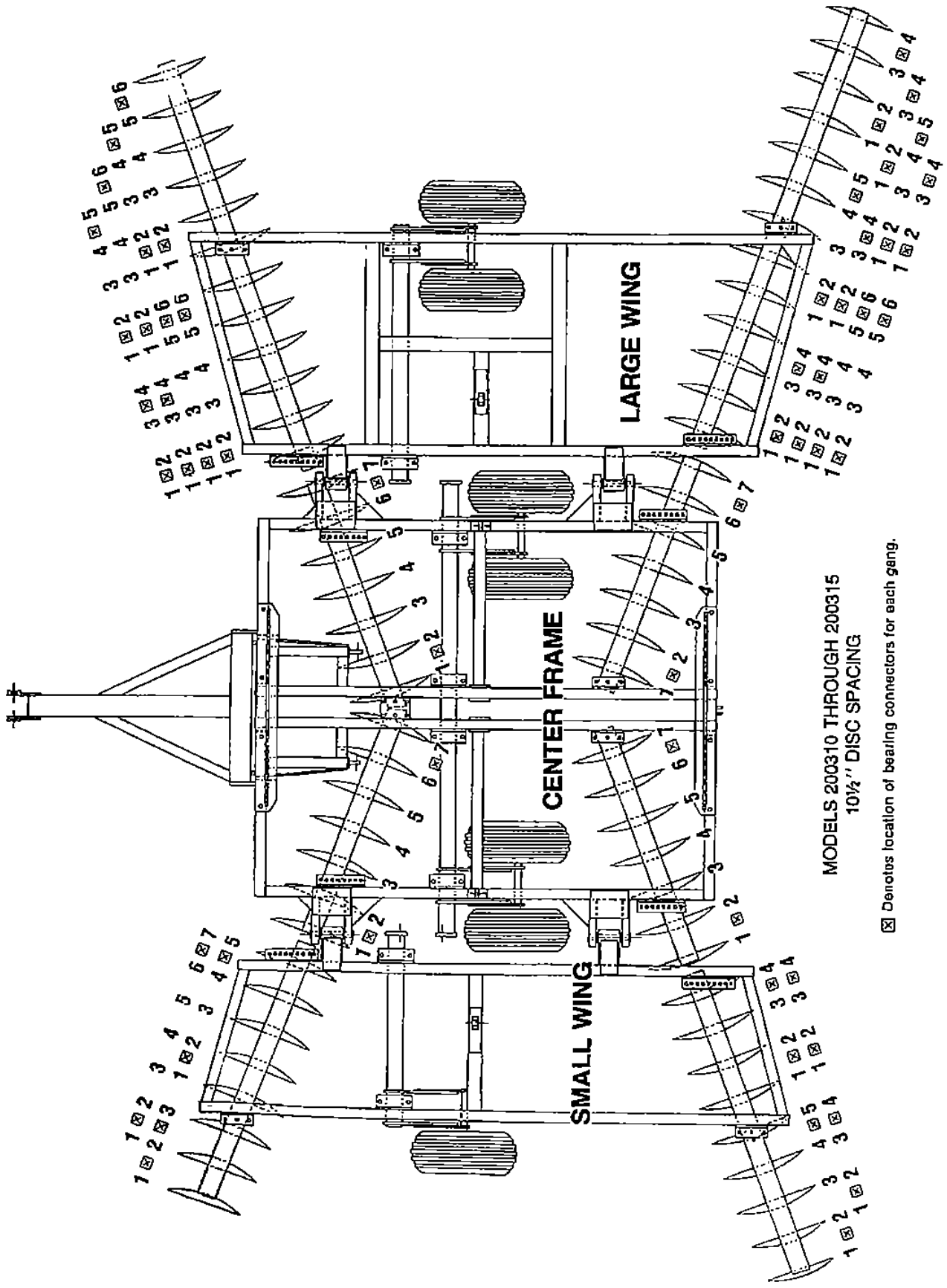

MODELS 200310 THROUGH 200315
10 1/2" DISC SPACING

☐ Denotes location of bearing connectors for each gang.

MAIN FRAME DISC GANG BUNDLES

MODELS 200310 -- 200315

MODEL NO.	BUNDLE NUMBERS FOR RIGID BEARING CONNECTOR	BUNDLE NUMBERS FOR SPRING BEARING CONNECTOR
200310-315	Right Front, 7-Disc, 201674	Right Front, 7-Disc, 201884
200310-315	Left Front, 7-Disc, 201675	Left Front, 7-Disc, 201885
200310-315	Right Rear, 7-Disc, 201676	Right Rear, 7-Disc, 201886
200310-315	Left Rear, 7-Disc, 201677	Left Rear, 7-Disc, 201887

SMALL WING DISC GANG BUNDLES
MODELS 200310 & 200311

MODEL NO.	BUNDLE NUMBERS FOR RIGID BEARING CONNECTOR	BUNDLE NUMBERS FOR SPRING BEARING CONNECTOR
200310	Right Front, 7-Disc, 201678	
200310	Left Front, 7-Disc, 201679	
200310	Right Rear, 8-Disc, 201680	
200310	Left Rear, 8-Disc, 201681	
200310		Right Front, 7-Disc, 201888
200310		Left Front, 7-Disc, 201889
200310		Right Rear, 8-Disc, 201890
200310		Left Rear, 8-Disc, 201891
200311		Right Front, 8-Disc, 201892
200311		Left Front, 8-Disc, 201893
200311		Right Rear, 9-Disc, 201894
200311		Left Rear, 9-Disc, 201895

LARGE WING DISC GANG BUNDLES
MODELS 200312 -- 200315

MODEL NO.	BUNDLE NUMBERS FOR RIGID BEARING CONNECTOR	BUNDLE NUMBERS FOR SPRING BEARING CONNECTOR
200312	Right Front, 9-Disc, 201686	Right Front, 9-Disc, 201686
200312	Left Front, 9-Disc, 201687	Left Front, 9-Disc, 201687
200312	Right Rear, 10-Disc, 201688	Right Rear, 10-Disc, 201688
200312	Left Rear, 10-Disc, 201689	Left Rear, 10-Disc, 201689
200312		Right Front, 9-Disc, 201896
200312		Left Front, 9-Disc, 201897
200312		Right Rear, 10-Disc, 201898
200312		Left Rear, 10-Disc, 201899
200313		Right Front, 10-Disc, 201690
200313		Left Front, 10-Disc, 201691
200313		Right Rear, 11-Disc, 201692
200313		Left Rear, 11-Disc, 201693
200313		Right Front, 10-Disc, 201900
200313		Left Front, 10-Disc, 201901
200313		Right Rear, 11-Disc, 201902
200313		Left Rear, 11-Disc, 201903
200314		Right Front, 11-Disc, 201694
200314		Left Front, 11-Disc, 201695
200314		Right Rear, 12-Disc, 201696
200314		Left Rear, 12-Disc, 201697
200314		Right Front, 11-Disc, 201904
200314		Left Front, 11-Disc, 201905
200314		Right Rear, 12-Disc, 201906
200314		Left Rear, 12-Disc, 201907
200315		Right Front, 12-Disc, 201698
200315		Left Front, 12-Disc, 201699
200315		Right Rear, 13-Disc, 201700
200315		Left Rear, 13-Disc, 201701
200315		Right Front, 12-Disc, 201908
200315		Left Front, 12-Disc, 201909
200315		Right Rear, 13-Disc, 201910
200315		Left Rear, 13-Disc, 201911

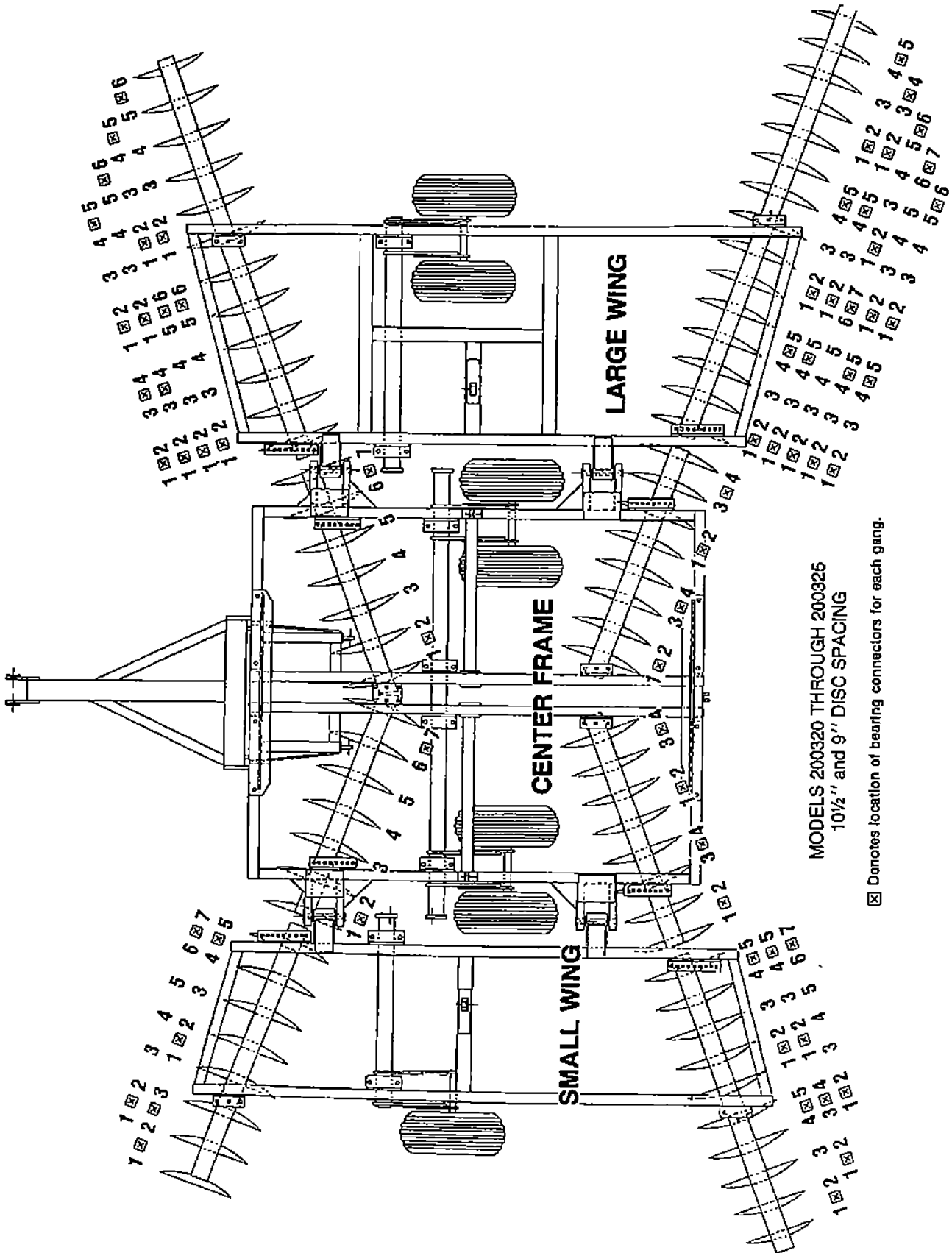

MODELS 200320 THROUGH 200325
 10 1/2" and 9" DISC SPACING

☒ Denotes location of bearing connectors for each gang.

**CENTER FRAME DISC GANG BUNDLES
MODELS 200320 — 200325**

MODEL NO.	BUNDLE NUMBERS FOR	
	RIGID BEARING CONNECTOR	SPRING BEARING CONNECTOR
200320-325	Right Front, 7-Disc, 201674	Right Front, 7-Disc, 201884
200320-325	Left Front, 7-Disc, 281675	Left Front, 7-Disc, 201885
200320-325	Right Rear, 8-Disc, 201985	Right Rear, 8-Disc, 201972
200320-325	Left Rear, 8-Disc, 201986	Left Rear, 8-Disc, 201973

**SMALL WING DISC GANG BUNDLES
MODELS 200320 — 200321**

MODEL NO.	BUNDLE NUMBERS FOR	
	RIGID BEARING CONNECTOR	SPRING BEARING CONNECTOR
200320	Right Front, 7-Disc, 201678	Right Front, 7-Disc, 201888
200320	Left Front, 7-Disc, 201679	Left Front, 7-Disc, 201889
200320	Right Rear, 9-Disc, 201993	Right Rear, 9-Disc, 201930
200320	Left Rear, 9-Disc, 201994	Left Rear 9-Disc, 201931
200321	Right Front, 8-Disc, 201682	Right Front, 8-Disc, 201892
200321	Left Front, 8-Disc, 201683	Left Front, 8-Disc, 201893
200321	Right Rear, 10-Disc, 201997	Right Rear, 10-Disc, 201934
200321	Left Rear, 10-Disc, 201998	Left Rear, 10-Disc, 201935

**LARGE WING DISC GANG BUNDLES
MODELS 200322 — 200325**

MODEL NO.	BUNDLE NUMBERS FOR	
	RIGID BEARING CONNECTOR	SPRING BEARING CONNECTOR
200322	Right Front, 9-Disc, 201686	Right Front, 9-Disc, 201896
200322	Left Front, 9-Disc, 201687	Left Front, 9-Disc, 201897
200322	Right Rear, 12-Disc, 202005	Right Rear, 12-Disc, 201942
200322	Left Rear, 12-Disc, 202006	Left Rear, 12-Disc, 201943
200322	Right Front, 10-Disc, 201690	Right Front, 10-Disc, 201900
200322	Left Front, 10-Disc, 201691	Left Front, 10-Disc, 201901
200323	Right Rear, 13-Disc, 202009	Right Rear, 13-Disc, 201946
200323	Left Rear, 13-Disc, 202010	Left Rear, 13-Disc, 201947
200324	Right Front, 11-Disc, 201694	Right Front, 11-Disc, 201904
200324	Left Front, 11-Disc, 201695	Left Front, 11-Disc, 201905
200324	Right Rear, 14-Disc, 202013	Right Rear, 14-Disc, 201950
200324	Left Rear, 14-Disc, 202014	Left Rear, 14-Disc, 201951
200325	Right Front, 12-Disc, 201698	Right Front, 12-Disc, 201908
200325	Left Front, 12-Disc, 201699	Left Front, 12-Disc, 201909
200325	Right Rear, 15-Disc, 202017	Right Rear, 15-Disc, 201954
200325	Left Rear, 15-Disc, 202018	Left Rear, 15-Disc, 201955

SETTING-UP INSTRUCTIONS

Hydraulic Folding — Flexible Wheel Tandem Harrow

General

Right and left are determined by standing at the rear of the harrow. All items designated as right and left fit into their respective positions on the front section. When used on the rear section, the procedure is reversed and items designated as right will fit onto the left side and vice versa.

These harrows are shipped "Knocked Down" and are bundled as shown on pages 10 through 13.

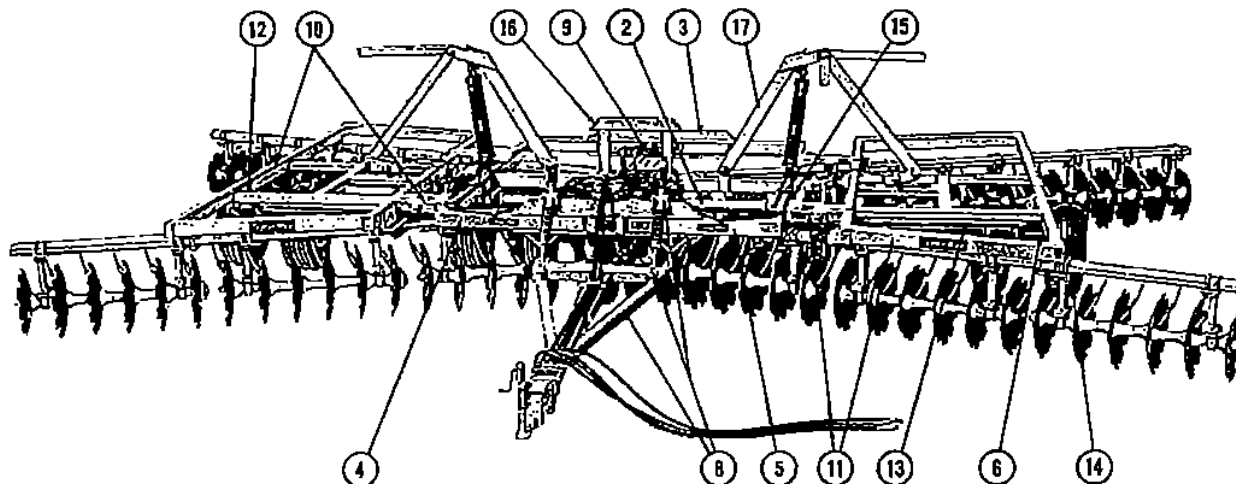

FIG. 14

Basic Harrow Assembly

1. When setting up unit refer to parts lists and diagrams on preceding pages to identify descriptions of parts and assemblies. Also, refer to bundle list to identify the bundles that are used on your particular harrow. Remove all bundling wire and proceed as follows: Remember right and left are determined by viewing from the rear of harrow.
2. Position the main frame wheel axle, bundle number 202041, in the center of the work area with the axles for rim toward the rear and the hydraulic cylinder connector bracket upward.
3. Place the center frame bundle, bundle number 201883, approximately four feet from the ground and over the main frame wheel axle bundle. Remove the eight $\frac{3}{8}$ " x $7\frac{1}{2}$ " bolts from the center frame bundle.
4. Remove the four bolts and plate from the center tube of right main frame. Slide the right main frame, bundle number 201970, between the two flats on the right side of center frame. The front of the right main frame is determined by aligning the bracket for the main frame wheel axle across the unit. Align the holes in the right main frame front and rear tube to match the holes in the center frame bundle. Replace the four $\frac{3}{8}$ " x $7\frac{1}{2}$ " bolts previously removed. Replace the plate and four bolts removed connecting the right main frame to center frame.
5. Repeat procedures in step 4 to connect the left main frame, bundle number 201971, to center frame.
6. Remove the bolts connecting the wheel axle strap (Item 3, Fig. 1) from the center frame and the right and left main frame bundles. Turn the alemitone on the wheel axle bearing toward the rear, if they are not already in this position. Connect the main frame wheel axle to the center frame and right and left main frames.
7. Install the rims with rubber tires onto the hubs of main frame wheel axle.
8. Connect the tongue bundle, bundle number 201816 or 201982, to the center frame. Remove the two pins from the tongue bundle. Align the holes of the tongue to match the holes on the center frame and reinstall the pins. Connect the spring rods to the tongue with the pin found in the cuff end of the spring rod. Connect the other end of the spring rod to the center frame with the two $\frac{3}{8}$ " shoulder bolts found at the connecting points.
9. Insert the depth control bar between the flats on the rear of center frame. Place the other end of the depth control bar between the flats on wheel lift. Align holes and connect with bolt provided.
10. Remove the wing hinge pins and bushings from the right main frame. Insert the bushings in both the front and rear hinges of right wing frame. Align the wing hinge with the hinges on the right main frame and connect with pins previously removed.
11. Repeat procedures in step 10 to connect the left wing frame to the left side of main frame.
12. Remove the bolts from the right wing wheel axle bearing and strap. With the bearing (Item 4, Fig. 1) on top of wheel lift, raise the wheel lift and connect to wing frame with bolts and straps provided.
13. Repeat step 12 for connecting left wing wheel axle.
14. Mount rims with rubber tires on both wing wheel axle hubs.
15. Install the wing wheel axle connector between main frame wheel axle and wing wheel axle, by removing the pins, aligning the holes, and replacing the pins. Adjust the wheel axle connectors until the center frame and wing frames are level across the top when the harrow is setting on level ground.
16. Remove the bolts and bottom plates from the wing stop bundle, bundle number 201320. Place the wing stop over the center frame as shown in Fig. 14 and connect to the center tube of the right and left main frame. Secure the wing stop in place with bolts and plates previously removed.
17. Connect the cylinder arm of bundle number 201276 or 201479 to the main frame by removing the pin on center tube of main frame, aligning holes and reinserting the pin (see Fig. 14). Connect the radius arm and wing float rocker assembly to the right and left wings. Align the hole nearest the center of the rocker assembly, with the wing lift tube on wing frame. With the rocker in this position, the wing lift arm will be to the outside front.
Before going on to step 18 refer to page 16 for assembly of hydraulic cylinders and hoses.
18. If a tractor with hydraulic system is available, connect the hydraulic system to the harrow. Use the hydraulic cylinders on the unit to control the height of the harrow for connecting disc gang bundles. On pages 12, 13, and 14, are layouts of disc gang bundles with respect to harrow frame. Refer to these drawings for correct disc gang placement. Raise or lower the harrow frame to the gang bundle and connect with bolts and plates provided. The angle of the gangs can be changed by a series of holes on the outside gang connector bracket. NOTE: Always place the front gangs in the same angle. Always place the rear gangs in same angle. The front and rear gangs can be at different angles to each other.
19. Adjust and tighten all scrapers. Tighten all bolts and spread all cotters.
20. Retighten all lug bolts after the harrow has been used to insure they are still tight.

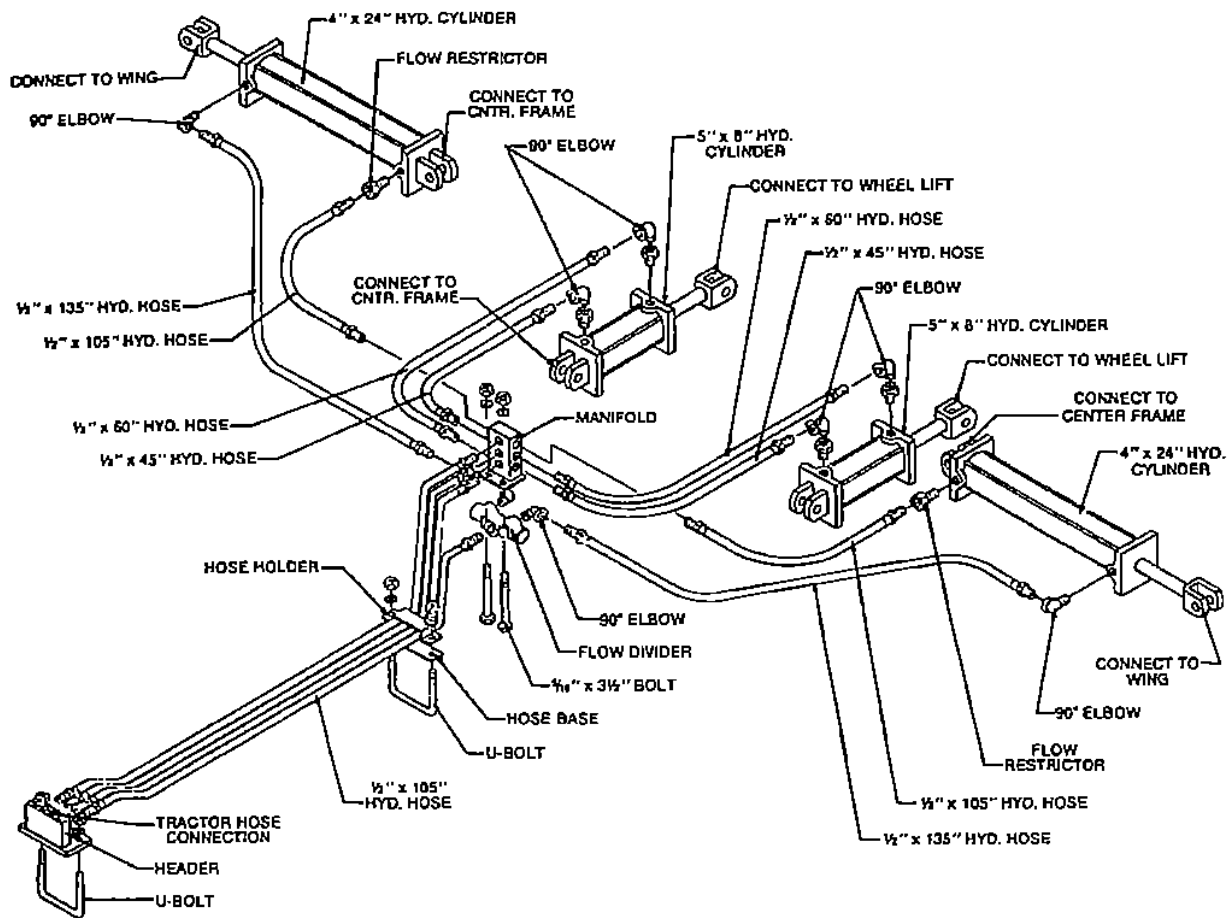

FIG. 15 — HYDRAULIC CYLINDER and HOSE ASSEMBLY

1. Connect the base of two 5" x 8" hydraulic cylinders to the bracket on the main frame, and rod end to floating bracket on the wheel lift.
2. Connect the base of the two 4" x 24" hydraulic cylinders to cylinder bracket on main frame with the hose ports facing to the front of unit. Insert six 90° elbows into hose ports of wheel lift cylinders and wing lift cylinders, using four elbows in wheel lift cylinders, and two elbows in rod end of wing cylinders (see Fig. 15). Insert two flow restrictors into butt end of wing cylinders.
3. Bolt the flow divider and manifold to front of center frame using 5/16" x 3 1/4" bolts, lockwashers, and nuts provided. Next insert a 1" to 1/2" adapter to front of flow divider. Then, insert two 3/4" to 1/2" adapters to rear of flow divider. Insert two 90° elbows into the 3/4" to 1/2" adapters, just installed. When tightened the elbow ports should be turned to outside of harrow.
4. Each hose has only one swivel so it is important to screw the end of hose without swivel in first. Always tighten each hose end

immediately after connection. This is very important on manifold and header because the holes are very close together. Screw two 1/2" x 45" hoses into butt end of wheel lift cylinders. Remember to tighten. Screw the other end in the bottom holes on side of manifold (see Fig. 15). Next, screw two 1/2" x 60" hydraulic hoses into the rod end of wheel lift cylinders, and into the middle hole of manifold. Tighten both ends of hose. Then connect two 1/2" x 105" hoses to flow restrictor located in butt end of 4" x 24" wing lift cylinders. Screw the opposite end or swivel end to top hole of manifold. Next connect two 1/2" x 135" hoses to 90° elbow in rod end of 4" x 24" hydraulic cylinder, screw the opposite end into 90° elbow located in back side of flow divider. To complete hose assembly, connect remaining four 1/2" x 105" hoses to front of manifold and flow divider. Connect other end to header on front of tongue. Clamp hoses onto rear of tongue to hold hoses in place. Also, clamp all hoses to center frame with hose clamps provided (see Fig. 15).

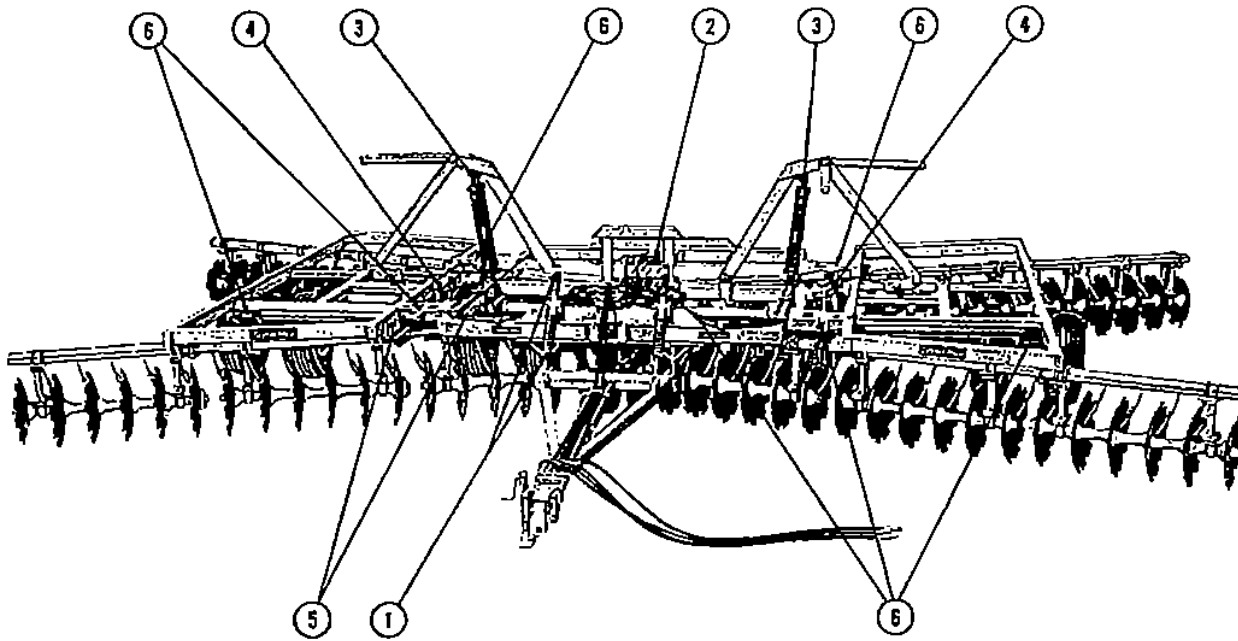

FIG. 16

OPERATING INSTRUCTIONS

Front to Rear Leveling

See Item 1, Figure 16

To level the harrow from front to rear, use the Spring Adjustment Rods, (Item 1, Fig. 16). Loosen the 1 $\frac{3}{8}$ " Nut so that no pressure is exerted on the Top Spring when the harrow is down and in its plowing position. Note: The Bottom Spring is easier to adjust when the harrow is in the transport position. With the Top Spring loose, tighten the Bottom spring by screwing up on the Nut located on the Spring Adjustment Rod to increase the cutting depth of the rear section. To decrease the cutting depth of the rear section, loosen the Bottom Spring by screwing down on the 1 $\frac{3}{8}$ " Nut. After the cutting depth has been adjusted, lift the harrow to its transport position and tighten the Top Spring by screwing down on the 1 $\frac{3}{8}$ " Nut located on top of the Spring Adjustment Rod until the harrow is approximately level.

Adjustment for Leveling Wing

See Item 4, Fig. 16

The wing frame and center frame should be level across the top of unit. If not, lower the harrow to plowing position. Loosen the wing lock nut on the wheel axle connector. Lengthen the wheel axle connector to lower the wing. Shorten the connector to raise the wing. When adjustment has been made, tighten the wing lock nut.

Adjustment of Wing Float

See Item 3, Fig. 16

The wing can be adjusted to have more floating action in the up or down direction. By screwing the hydraulic cylinder cuff "in" for more floating in the down direction and screwing the hydraulic cylinder cuff "out" for more floating in the up direction.

Adjustment for Disc Angle

See Item 5, Fig. 16

The disc angle is changed by removing the two $\frac{1}{2}$ " x 5 $\frac{1}{2}$ " bolts and gang connector strap on the outside of the center section gangs and the inside of the wing gangs. Slide the gangs to the desired angle and replace the straps and bolts previously removed. Always have the same amount of angle in the front gang assemblies and the same amount of angle in the rear gang assemblies.

Adjusting for Ridging or Furrowing

Loosen the U-Bolts holding the bearing connectors and the scraper bars on the rear gang frames. Move all rear disc gang assemblies out if

the harrow is ridging and if the harrow is not filling up the furrow left by the center of the front gangs. Make sure that all U-Bolts are moved the same distance toward or away from the center of the harrow. The speed that the harrow is pulled will affect these adjustments, therefore, adjustments should be made for the speed that the harrow will normally be pulled.

Adjusting for Balk

Loosen the U-Bolts holding the bearing connectors and the scraper bars on the front gang frame. Move all front disc gang assemblies (Fig. 4) in toward the center until the butt plates (Item 10, Fig. 2) are touching. Make sure all U-Bolts are moved the same distance toward the center before tightening. Loosen the U-Bolt holding the bearing connector and the scraper bars on the wing and slide in toward the center until the 9" or 10 $\frac{1}{2}$ " spacing is between the disc on the center section and the wing section.

Depth of Cut

See Item 2, Fig. 16

The depth of cut is controlled by the use of two ASAE standard 5" x 8" double action hydraulic cylinders or by using the depth adjustment bar, cuff, pin and cotter. To adjust the depth of cut using the depth adjustment bar, remove the depth adjustment pin and cotter and slide the depth adjustment cuff forward on depth bar to decrease the depth of cut and to the rear to increase the depth of cut. For transport, move the depth adjustment cuff to the foremost hole. Never pin the depth adjustment cuff in front of the slide which the depth adjustment bar travels through on the rear of the harrow. Also, do not place a wedge or any other object between the rear hydraulic cylinder bracket and the bracket holder welded to the wheel axle to make the harrow lift higher in the transport position.

Lubrication

See Item 6, Fig. 16

The bearings (Item 7 and 9, Fig. 5) used in the wheel hub assemblies are packed with grease at the factory prior to shipment. These bearings should be checked and adjusted periodically and repacked with grease. The harrow should be greased at all Alemite fittings as often as necessary to insure ease of operation and long life of the working parts. (Approx. 300 to 400 hrs.) These points are indicated as (Item 6, Fig. 16). The ball bearings (Item 22, Fig. 2) are regreaseable ball bearings and should be greased daily when operating.

Gang Coupler Attachment

MACHINERY NO. 200093

1. Remove the nut, washer and end washer (Items 1, 2, 3 and 4, Fig. 2) from the axle (Item 17, Fig. 2) in the opening where the two axles are to be connected. Slip the axle (Item 17, Fig. 2) back approximately $1\frac{1}{2}$ ". This will give sufficient clearance to install the coupler. *On the front gangs, start on the outside and work to the inside. On the rear gangs start on the inside and work to the outside.*
2. With the bolts provided, mount the butt plate driver (Item 2, Fig. 3) to the butt plate (Item 14, Fig. 2). Tighten all bolts evenly and securely. Replace the end washer (Item 4, Fig. 2) with the end washer drive (Item 3, Fig. 3) of the coupler.
3. Slip the axle back into its original position and replace the washer and nut (Item 1 and 3, Fig. 2). Tighten securely.

Tightening of Disc Axles

The axles and disc gangs are assembled at the factory prior to shipment. The disc axles (Item 17, Fig. 2) have been tightened sufficiently at the factory. During the first few hours of operation the discs and disc spacer will seat themselves, which tends to loosen the disc axles. After this initial "run in" the disc axles should be retightened to a minimum of 1000 lb.-ft. Unless the disc axle nut is removed for some reason, no further tightening should be necessary. To check the disc axle for looseness, place the harrow in transport position and strike each disc with a light hammer. If the disc has a ringing sound, the axle is tight.

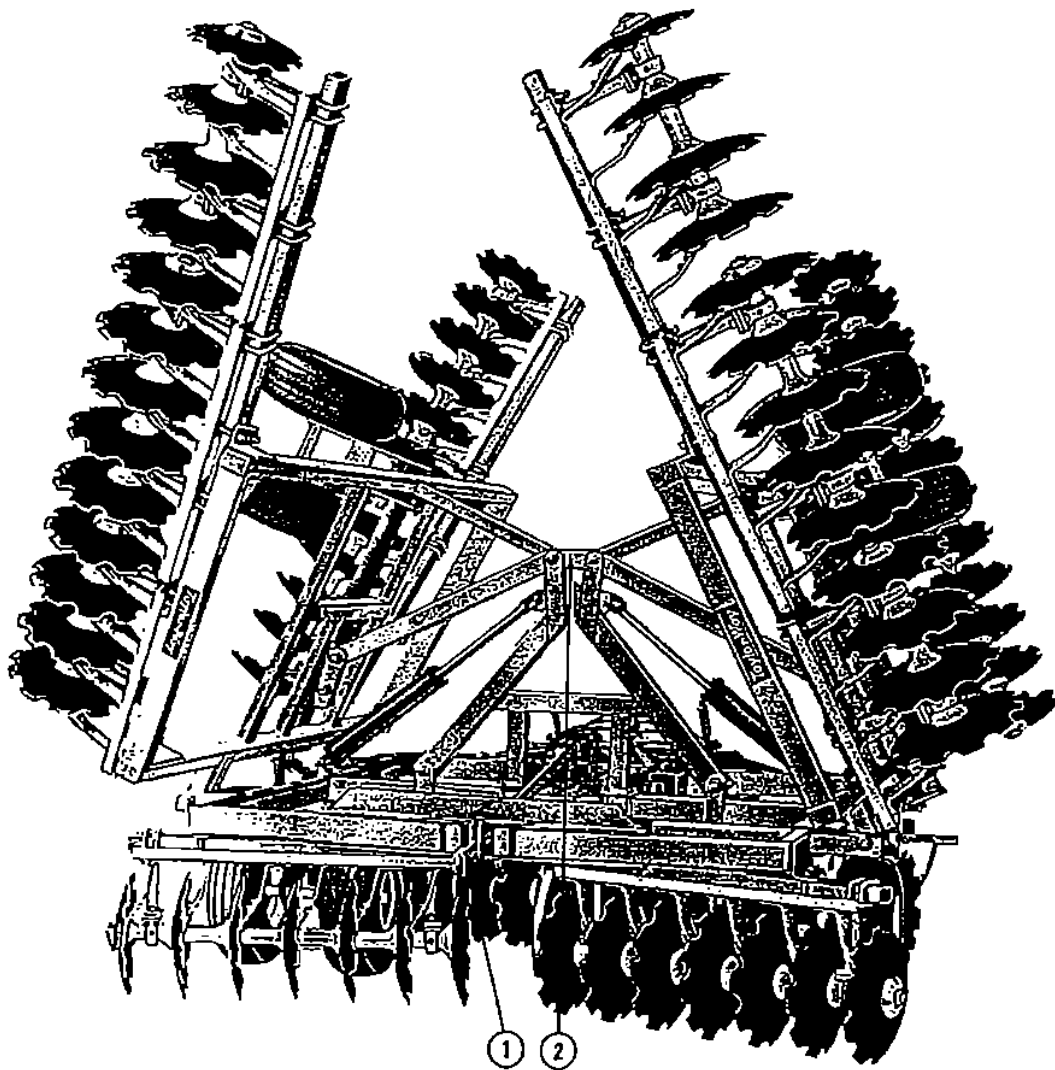

FIG. 17 — TRANSPORT POSITION

Transporting Harrow

See Item 1, Fig. 17

Pin the depth control bar in transport position when transporting. Remove the depth adjustment pin and the depth adjustment cuff. Position the depth adjustment cuff over the hole closest to the front of the unit and replace the depth adjustment pin.

See Item 2, Fig. 17

When transporting the harrow at transport speeds always have the wing assemblies folded. Fold the wings and pin with the safety strap.

TAYLOR IMPLEMENT DIVISION
PITTSBURGH FORGINGS CO.
TRACTOR DRAWN *Taylor-Way* REG. U.S. PAT. OFF. IMPLEMENTS

ATHENS, TENNESSEE 37303—TELEPHONE (AREA CODE 615) 745-3110