

Taylor-Way

REG. U. S. PAT. OFF.

PARTS LIST

Setting-up and Operating Instructions for WHEEL MOUNTED TANDEM HARROW

Model Number	No. of Discs	Disc Spacing	Width of Cut Ft. & In. Meters		Approximate Weight								Suggested G. B. H. P.
					7 1/2" (19.05 C.M.) or 9" (22.86 C.M.) Disc Spacing				11" (2.8 C.M.) Square Axle				
					18" C. O.		20" C. O.		22" C. O.		24" C. O.		
Lbs.	K.G.	Lbs.	K.G.	Lbs.	K.G.	Lbs.	K.G.						
200108	16	9"	8' 6"	2.58	1600	725	1660	750	1715	775	1810	820	35
200109	20	9"	7' 11"	2.41	1770	800	1840	835	1910	865	2030	920	40
200110	24	9"	9' 4"	2.84	1940	880	2020	915	2105	945	2250	1020	45
200119	28	9"	10' 9"	3.27	2140	970	2235	1010	2335	1060	2505	1135	50
200100	32	9"	12' 2"	3.70	2785	1260	2900	1315	3010	1365	3205	1450	60
200101	36	9"	13' 7"	4.13	2925	1315	3035	1375	3180	1430	3375	1530	70
200111	20	7 1/2"	8' 11"	2.70	1670	755	1740	790	1810	820	1930	875	35
200112	24	7 1/2"	8' 1"	2.46	1835	830	1920	870	2005	910	2150	975	40
200113	28	7 1/2"	9' 3"	2.81	2005	910	2105	955	2200	995	2370	1075	45
200120	32	7 1/2"	10' 5"	3.17	2205	1000	2315	1050	2430	1100	2620	1185	50
200102	40	7 1/2"	12' 10"	3.90	2920	1320	3060	1385	3200	1450	3440	1560	60
200103	44	7 1/2"	14' 0"	4.26	3070	1390	3220	1460	3375	1530	3640	1650	70
200114	8F, 10R	9" F, 7 1/2" R	6' 11"	2.10	1635	740	1700	770	1760	795	1870	845	35
200115	10F, 12R	9" F, 7 1/2" R	8' 1"	2.46	1805	820	1890	850	1955	885	2090	945	40
200116	12F, 14R	9" F, 7 1/2" R	9' 3"	2.81	1970	890	2060	935	2155	975	2310	1045	45
200121	14F, 16R	9" F, 7 1/2" R	10' 5"	3.17	2170	985	2275	1030	2380	1080	2560	1160	50
200117	16F, 20R	9" F, 7 1/2" R	12' 10"	3.90	2820	1275	2945	1335	3070	1390	3285	1490	60
200118	18F, 22R	9" F, 7 1/2" R	14' 0"	4.26	2990	1355	3125	1415	3280	1485	3520	1595	70

The outside disc of each gang on the above implements is tapered 2" except implements equipped with 18" discs. See Furrow Filler Attachment under Extra Equipment for additional taper on rear gangs. Above implements shipped with 15" x 8" Rims. Tires and Hydraulic Cylinders not furnished.

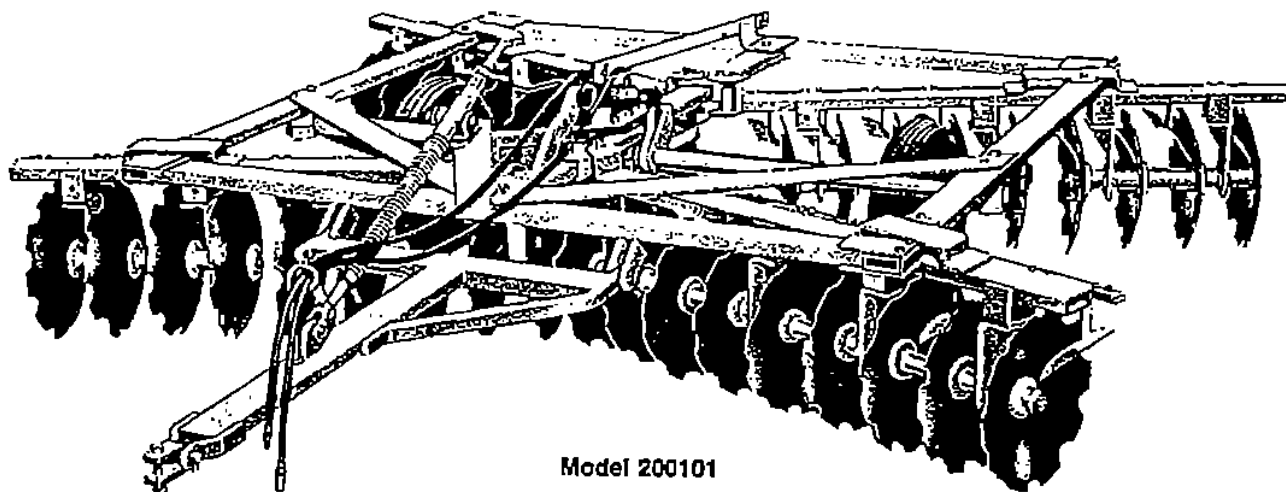

Model 200101

TAYLOR IMPLEMENT DIVISION

PITTSBURGH FORGINGS CO.

TRACTOR DRAWN *Taylor-Way* IMPLEMENTS
REG. U. S. PAT. OFF.

ATHENS, TENNESSEE 37303-TELEPHONE (AREA CODE 615) 745-3110

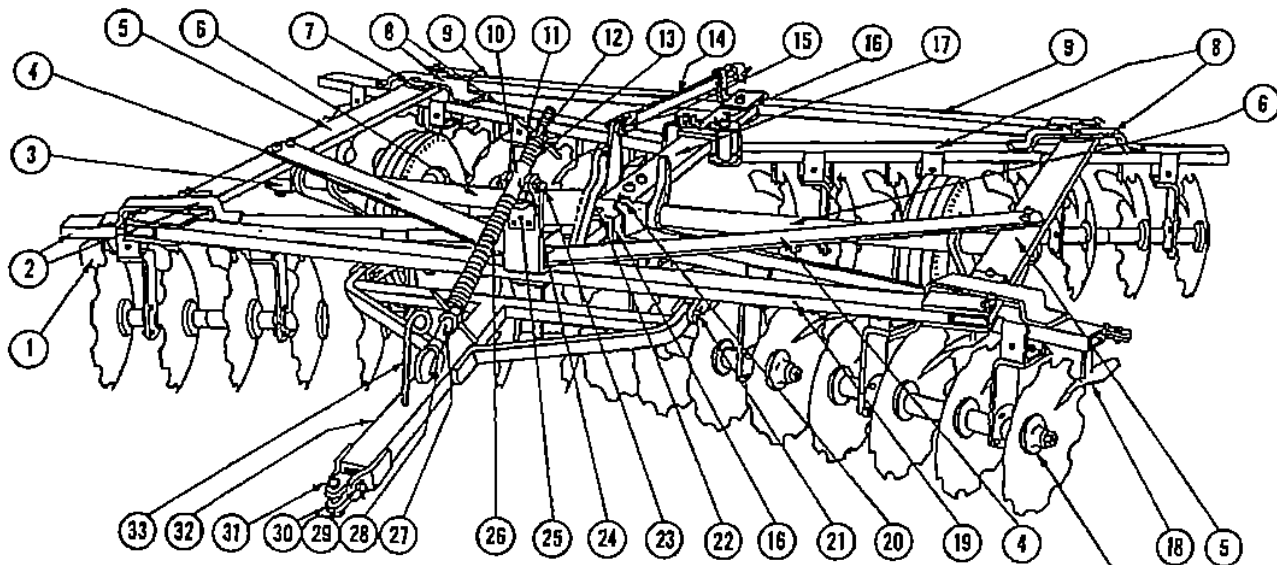
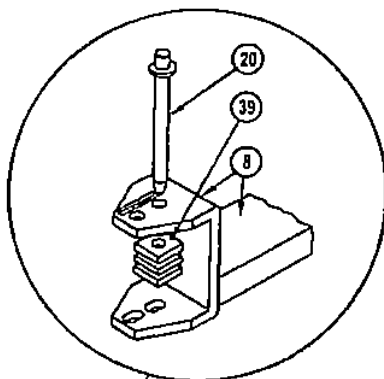

FIG. 1 — MODEL 200101 WHEEL MOUNTED TANDEM HARROW



DISC GANG ASSEMBLY —
SEE FIG. 3

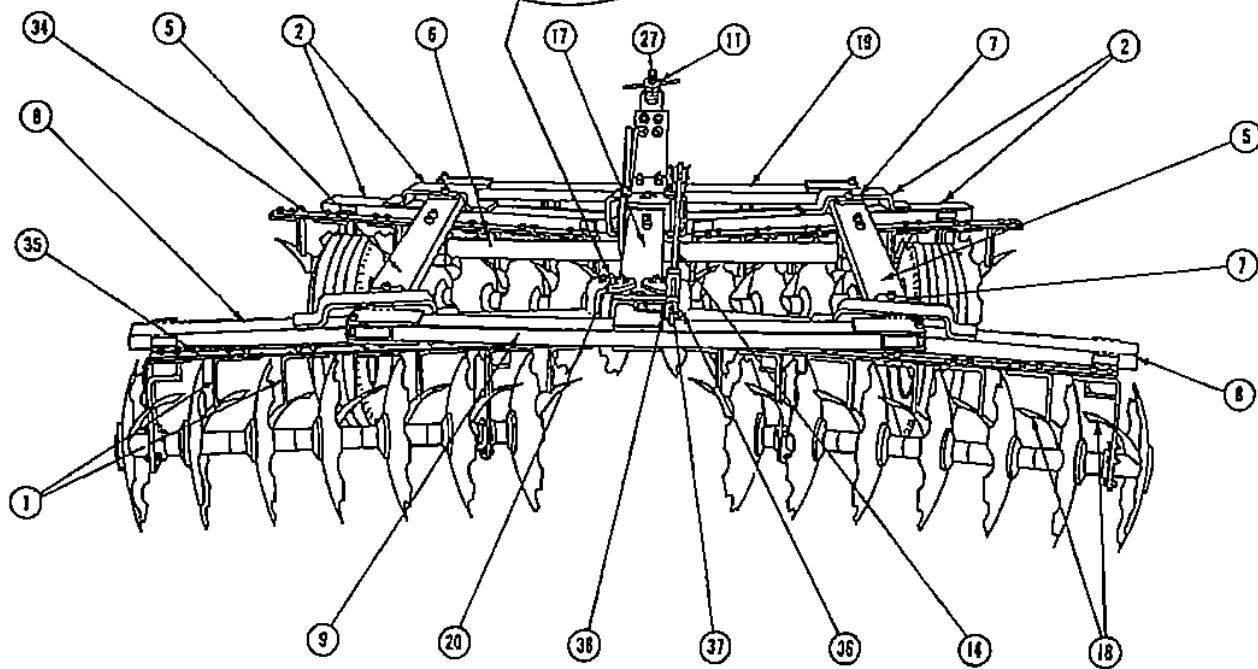

FIG. 2 — MODEL 200113 WHEEL MOUNTED TANDEM HARROW

Item No.	Part No.	PARTS LIST FOR WHEEL MOUNTED TANDEM MODELS																Description	Size		
		200108	200109	200110	200119	200100	200101	200111	200112	200113	200120	200102	200103	200114	200115	200116	200121			200117	200118
1.	204909	8	10	12	14	16	18	10	12	14	16	20	22	9	11	13	15	18	20	Right Scraper	
		16	20	24	28	32	36	20	24	28	32	40	44	18	22	26	30	36	40	Bolt W/Nut	1/2" x 1 1/2"
		16	20	24	28	32	36	20	24	28	32	40	44	18	22	26	30	36	40	Lock Washer	1/2"
2.	205185	2	0	0	0	0	0	0	0	0	0	0	0	2	0	0	0	0	0	Front Gang Frame	
		0	2	0	0	0	0	0	0	0	0	0	0	0	2	0	0	0	0	Front Gang Frame	
		0	0	2	0	0	0	0	0	0	0	0	0	0	0	2	0	0	0	Front Gang Frame	
		0	0	0	2	0	0	0	0	0	0	0	0	0	0	0	2	0	0	Front Gang Frame	
		0	0	0	0	2	0	0	0	0	0	0	0	0	0	0	0	2	0	Front Gang Frame	
		0	0	0	0	0	2	0	0	0	0	0	0	0	0	0	0	0	2	Front Gang Frame	
		0	0	0	0	0	0	2	0	0	0	0	0	0	0	0	0	0	0	Front Gang Frame	
		0	0	0	0	0	0	0	2	0	0	0	0	0	0	0	0	0	0	Front Gang Frame	
		0	0	0	0	0	0	0	0	2	0	0	0	0	0	0	0	0	0	Front Gang Frame	
		0	0	0	0	0	0	0	0	0	2	0	0	0	0	0	0	0	0	Front Gang Frame	
		0	0	0	0	0	0	0	0	0	0	2	0	0	0	0	0	0	0	Front Gang Frame	
		0	0	0	0	0	0	0	0	0	0	0	2	0	0	0	0	0	0	Front Gang Frame	
		0	0	0	0	0	0	0	0	0	0	0	0	2	0	0	0	0	0	Front Gang Frame	
		3.	205032	6	6	6	6	6	6	6	6	6	6	6	6	6	6	6	6	6	Lift Roll Bearing
3	3			3	3	3	3	3	3	3	3	3	3	3	3	3	3	3	Atomite, Straight Drive in W"		
4.	205153	0	0	0	0	2	2	0	0	0	0	2	2	0	0	0	0	2	Top Brace		
5.	205171	2	2	2	2	0	0	2	2	2	2	2	0	2	2	2	2	0	Side Frame — Repairs Only		
		2	2	2	2	2	2	2	2	2	2	2	2	2	2	2	2	2	Side Frame		
		4	4	4	4	0	0	4	4	4	4	0	4	4	4	4	4	0	Bolt W/Nut — Repairs	3/4" x 7"	
6.	205180	4	4	4	4	4	4	4	4	4	4	4	4	4	4	4	4	4	Bolt W/Nut	3/4" x 7 1/2"	
		4	4	4	4	4	4	4	4	4	4	4	4	4	4	4	4	4	Lock Washer	3/4"	
		1	1	1	1	0	0	1	1	1	1	0	0	1	1	1	1	0	Wheel Lift		
7.	205038	0	0	0	0	1	1	0	0	0	0	1	1	0	0	0	0	1	Wheel Lift for Dual Wheels		
		0	0	0	0	1	1	0	0	0	0	1	1	0	0	0	0	1	Wheel Lift		
		1	1	1	1	0	0	1	1	1	1	0	0	1	1	1	1	0	Wheel Lift for Dual Wheels		
		1	1	1	1	1	1	1	1	1	1	1	1	1	1	1	1	1	Rear Hydraulic Cylinder Bracket		
		1	1	1	1	1	1	1	1	1	1	1	1	1	1	1	1	1	Tension Bushing	1" ID x W"W	
		4	4	4	4	4	4	4	4	4	4	4	4	4	4	4	4	4	Stop		
8.	205188	4	4	4	4	4	4	4	4	4	4	4	4	4	4	4	4	4	Bolt W/Nut	3/4" x 3 1/2"	
		4	4	4	4	4	4	4	4	4	4	4	4	4	4	4	4	4	Lock Washer	3/4"	
		2	0	0	0	0	0	0	0	0	0	0	0	0	0	0	0	0	Rear Gang Frame		
		0	2	0	0	0	0	0	0	0	0	0	0	0	0	0	0	0	Rear Gang Frame		
		0	0	2	0	0	0	0	0	0	0	0	0	0	0	0	0	0	Rear Gang Frame		
		0	0	0	2	0	0	0	0	0	0	0	0	0	0	0	0	0	Rear Gang Frame		
		0	0	0	0	2	0	0	0	0	0	0	0	0	0	0	0	0	Rear Gang Frame		
		0	0	0	0	0	2	0	0	0	0	0	0	0	0	0	0	0	Rear Gang Frame		
		0	0	0	0	0	0	2	0	0	0	0	0	0	2	0	0	0	Rear Gang Frame		
		0	0	0	0	0	0	0	2	0	0	0	0	0	0	2	0	0	Rear Gang Frame		
		0	0	0	0	0	0	0	0	2	0	0	0	0	0	0	2	0	Rear Gang Frame		
		0	0	0	0	0	0	0	0	0	2	0	0	0	0	0	0	2	Rear Gang Frame		
		0	0	0	0	0	0	0	0	0	0	2	0	0	0	0	0	0	Rear Gang Frame		
		9.	205178	1	1	1	1	0	0	1	1	1	1	0	0	1	1	1	1	0	Rear Cross Frame
0	0			0	0	1	1	0	0	0	1	1	0	0	0	0	1	1	Rear Cross Frame		
4	4			4	4	4	4	4	4	4	4	4	4	4	4	4	4	4	Bolt W/Nut	3/4" x 3 1/2"	
1	1			1	1	1	1	1	1	1	1	1	1	1	1	1	1	1	Bolt W/Nut	3/8" x 4"	
4	4			4	4	4	4	4	4	4	4	4	4	4	4	4	4	4	Lock Washer	3/4"	
10.	205314	1	1	1	1	1	1	1	1	1	1	1	1	1	1	1	1	Lock Washer	3/4"		
		1	1	1	1	1	1	1	1	1	1	1	1	1	1	1	1	Spring Rod Slide			
11.	204966	1	1	1	1	1	1	1	1	1	1	1	1	1	1	1	1	Spring Adjustment			
12.	205163	2	2	2	2	2	2	2	2	2	2	2	2	2	2	2	2	Special Washer (not shown)			
13.	204969	1	1	1	1	1	1	1	1	1	1	1	1	1	1	1	1	Spring			
14.	205183	1	1	1	1	0	0	1	1	1	1	0	0	1	1	1	1	0	Transport Bar — Repairs Only		
		1	1	1	1	1	1	1	1	1	1	1	1	1	1	1	1	1	Transport Bar		
15.	204215	1	1	1	1	1	1	1	1	1	1	1	1	1	1	1	1	Pin			
		2	2	2	2	2	2	2	2	2	2	2	2	2	2	2	2	Cotter	5/16" x 1 1/2"		
16.	204988	2	2	2	2	2	2	2	2	2	2	2	2	2	2	2	2	Angling Slide — Repairs Only			
17.	205172	1	1	1	1	0	0	1	1	1	1	0	0	1	1	1	1	0	Center Frame — Repairs Only		
		1	1	1	1	1	1	1	1	1	1	1	1	1	1	1	1	1	Center Frame		
		1	1	1	1	0	0	1	1	1	1	0	0	1	1	1	1	0	Spacer (not shown)		
		0	0	0	0	1	1	0	0	0	0	1	1	0	0	0	0	1	Spacer (not shown)		
		2	2	2	2	2	2	2	2	2	2	2	2	2	2	2	2	2	Bolt W/Nut	3/4" x 8 1/2"	
		2	2	2	2	0	0	2	2	2	2	0	0	2	2	2	2	0	Bolt W/Nut — Repairs	3/4" x 8"	
18.	210648	1	1	1	1	1	1	1	1	1	1	1	1	1	1	1	1	Bolt W/Nut	3/4" x 4"		
		3	3	3	3	3	3	3	3	3	3	3	3	3	3	3	3	Lock Washer	3/4"		
		1	1	1	1	0	0	1	1	1	1	0	0	1	1	1	0	Spacer			

Item No.	Part No.	PARTS LIST FOR WHEEL MOUNTED TANDEM MODELS																		Description	Size		
		200108	200109	200110	200119	200100	200101	200111	200112	200113	200120	200102	200103	200114	200115	200116	200121	200117	200118				
18.	204911	8	10	12	14	16	18	10	12	14	16	20	22	9	11	13	15	18	20	Left Scraper			
		16	20	24	28	32	36	20	24	28	32	40	44	18	22	26	30	36	40	Bolt W/Nut	5/8" x 1 1/2"		
		16	20	24	28	32	36	20	24	28	32	40	44	18	22	26	30	36	40	Lock Washer	5/8"		
19.	205168 206790	16	20	24	28	32	36	20	24	28	32	40	44	18	22	26	30	36	40	Flat Washer	5/8"		
		1	1	1	1	0	0	1	1	1	1	1	0	0	1	1	1	1	0	0	Front Cross Frame		
		0	0	0	0	1	1	0	0	0	0	1	1	0	0	0	0	0	1	1	Front Cross Frame		
20.	206607	4	4	4	4	4	4	4	4	4	4	4	4	4	4	4	4	4	4	Bolt W/Nut	3/8" x 3 1/2"		
		4	4	4	4	0	0	4	4	4	4	0	0	4	4	4	4	0	0	Bolt W/Nut — Repairs	3/8" x 4"		
		4	4	4	4	4	4	4	4	4	4	4	4	4	4	4	4	4	4	4	Bolt W/Nut	3/8" x 5 1/2"	
21.	204041	8	8	8	8	8	8	8	8	8	8	8	8	8	8	8	8	8	8	Lock Washer	3/8"		
		4	4	4	4	4	4	4	4	4	4	4	4	4	4	4	4	4	4	4	Gang Hinge Pin		
		4	4	4	4	4	4	4	4	4	4	4	4	4	4	4	4	4	4	4	Cotter	5/16" x 1 1/2"	
22.	203929	2	2	2	2	2	2	2	2	2	2	2	2	2	2	2	2	2	2	Pin			
		4	4	4	4	4	4	4	4	4	4	4	4	4	4	4	4	4	4	4	Cotter	5/16" x 1 1/2"	
		4	4	4	4	4	4	4	4	4	4	4	4	4	4	4	4	4	4	4	Angling Pin — Repairs Only		
23.	203748	2	2	2	2	2	2	2	2	2	2	2	2	2	2	2	2	2	2	Cotter	5/16" x 1 1/2"		
		2	2	2	2	2	2	2	2	2	2	2	2	2	2	2	2	2	2	2	Shoulder Bolt		
		2	2	2	2	2	2	2	2	2	2	2	2	2	2	2	2	2	2	2	Lock Washer	3/8"	
24.	203739	1	1	1	1	1	1	1	1	1	1	1	1	1	1	1	1	1	1	Spring Swivel			
		1	1	1	1	1	1	1	1	1	1	1	1	1	1	1	1	1	1	1	Cotter	3/8" x 2"	
		1	1	1	1	1	1	1	1	1	1	1	1	1	1	1	1	1	1	1	Spring Rod Bearing Base		
25.	205322	4	4	4	4	4	4	4	4	4	4	4	4	4	4	4	4	4	4	Bolt W/Nut	3/8" x 2"		
		4	4	4	4	4	4	4	4	4	4	4	4	4	4	4	4	4	4	4	Lock Washer	3/8"	
		1	1	1	1	1	1	1	1	1	1	1	1	1	1	1	1	1	1	1	Spring		
26.	204364	1	1	1	1	1	1	1	1	1	1	1	1	1	1	1	1	1	1	Spring Rod			
		1	1	1	1	1	1	1	1	1	1	1	1	1	1	1	1	1	1	1	Pin		
		2	2	2	2	2	2	2	2	2	2	2	2	2	2	2	2	2	2	2	Cotter	5/16" x 1 1/2"	
27.	207473	1	1	1	1	1	1	1	1	1	1	1	1	1	1	1	1	1	1	Pin			
		1	1	1	1	1	1	1	1	1	1	1	1	1	1	1	1	1	1	1	Cotter	5/16" x 1 1/2"	
		2	2	2	2	2	2	2	2	2	2	2	2	2	2	2	2	2	2	2	Pin		
28.	203100	1	1	1	1	1	1	1	1	1	1	1	1	1	1	1	1	1	1	Pin			
		1	1	1	1	1	1	1	1	1	1	1	1	1	1	1	1	1	1	1	Cotter	5/16" x 1 1/2"	
		2	2	2	2	2	2	2	2	2	2	2	2	2	2	2	2	2	2	2	Pin		
29.	205260	1	1	1	1	1	1	1	1	1	1	1	1	1	1	1	1	1	1	Cotter	5/16" x 1 1/2"		
		2	2	2	2	2	2	2	2	2	2	2	2	2	2	2	2	2	2	2	Pin		
		2	2	2	2	2	2	2	2	2	2	2	2	2	2	2	2	2	2	2	Cotter	5/16" x 2"	
30.	205258	1	1	1	1	1	1	1	1	1	1	1	1	1	1	1	1	1	1	Clevis			
		1	1	1	1	1	1	1	1	1	1	1	1	1	1	1	1	1	1	1	Bolt W/Nut and Cotter		
		1	1	1	1	1	1	1	1	1	1	1	1	1	1	1	1	1	1	1	Tongue		
31.	203279	0	0	0	0	1	1	0	0	0	0	1	0	0	1	1	0	0	0	Tongue			
		0	0	0	0	1	1	0	0	0	0	1	0	0	1	1	0	0	0	0	Tongue		
		1	1	1	1	1	1	1	1	1	1	1	1	1	1	1	1	1	1	1	Flexible Hose Holder	1/2"	
32.	209934 209933	1	1	1	1	1	1	1	1	1	1	1	1	1	1	1	1	1	1	Flat Washer	1/2"		
		1	1	1	1	1	1	1	1	1	1	1	1	1	1	1	1	1	1	1	Lock Washer	1/2"	
		1	1	1	1	1	1	1	1	1	1	1	1	1	1	1	1	1	1	1	Nut	1/2"	
33.	205623 205043 205039 205206 205626 205049 205046 205209	0	0	0	2	0	0	0	0	0	0	0	0	0	0	0	0	1	0	0	3-Disc Rt. Scraper Bar, 9" Spacing		
		2	0	0	2	4	2	0	0	0	0	0	0	0	1	0	0	1	2	1	4-Disc Rt. Scraper Bar, 9" Spacing		
		0	2	0	0	0	2	0	0	0	0	0	0	0	0	1	0	0	0	1	5-Disc Rt. Scraper Bar, 9" Spacing		
		0	0	2	0	0	0	0	0	0	0	0	0	0	0	0	0	0	0	0	6-Disc Rt. Scraper Bar, 9" Spacing		
		0	0	0	0	0	0	0	0	0	4	0	0	0	0	0	0	2	0	0	4-Disc Rt. Scraper Bar, 7 1/2" Spacing		
		0	0	0	0	0	0	2	0	0	0	4	2	1	0	0	0	0	2	1	5-Disc Rt. Scraper Bar, 7 1/2" Spacing		
		0	0	0	0	0	0	0	2	0	0	0	2	0	1	0	0	0	0	1	6-Disc Rt. Scraper Bar, 7 1/2" Spacing		
		0	0	0	0	0	0	0	0	2	0	0	0	0	0	0	0	0	0	0	7-Disc Rt. Scraper Bar, 7 1/2" Spacing		
		4	4	4	8	8	8	4	4	4	8	8	8	4	4	4	8	8	8	8	Bolt W/Nut	3/8" x 1 1/2"	
		4	4	4	8	8	8	4	4	4	8	8	8	4	4	4	8	8	8	8	Lock Washer	3/8"	
		34.	205825 205045 205042 205208 205628 205051 205048 205211	0	0	0	2	0	0	0	0	0	0	0	0	0	0	0	1	0	0	3-Disc Lt. Scraper Bar, 9" Spacing	
				2	0	0	2	4	2	0	0	0	0	0	0	0	1	0	0	1	2	1	4-Disc Lt. Scraper Bar, 9" Spacing
0	2			0	0	0	2	0	0	0	0	0	0	0	0	1	0	0	0	1	5-Disc Lt. Scraper Bar, 9" Spacing		
0	0			2	0	0	0	0	0	0	0	0	0	0	0	1	0	0	0	1	6-Disc Lt. Scraper Bar, 9" Spacing		
0	0			0	0	0	0	0	0	0	4	0	0	0	0	0	0	2	0	0	4-Disc Lt. Scraper Bar, 7 1/2" Spacing		
0	0			0	0	0	0	2	0	0	0	4	2	1	0	0	0	0	2	1	5-Disc Lt. Scraper Bar, 7 1/2" Spacing		
0	0			0	0	0	0	0	2	0	0	0	2	0	1	0	0	0	0	1	6-Disc Lt. Scraper Bar, 7 1/2" Spacing		
0	0			0	0	0	0	0	0	2	0	0	0	0	0	0	1	0	0	0	7-Disc Lt. Scraper Bar, 7 1/2" Spacing		
4	4			4	8	8	8	4	4	4	8	8	8	4	4	4	8	8	8	8	Bolt W/Nut	3/8" x 1 1/2"	
4	4			4	8	8	8	4	4	4	8	8	8	4	4	4	8	8	8	8	Lock Washer	3/8"	
35.	209939 204683			1	1	1	1	1	1	1	1	1	1	1	1	1	1	1	1	1	1	Depth Bar Pin	
				1	1	1	1	1	1	1	1	1	1	1	1	1	1	1	1	1	1	1	Depth Adjustment Cuff
		1	1	1	1	1	1	1	1	1	1	1	1	1	1	1	1	1	1	1	Special Cotter		

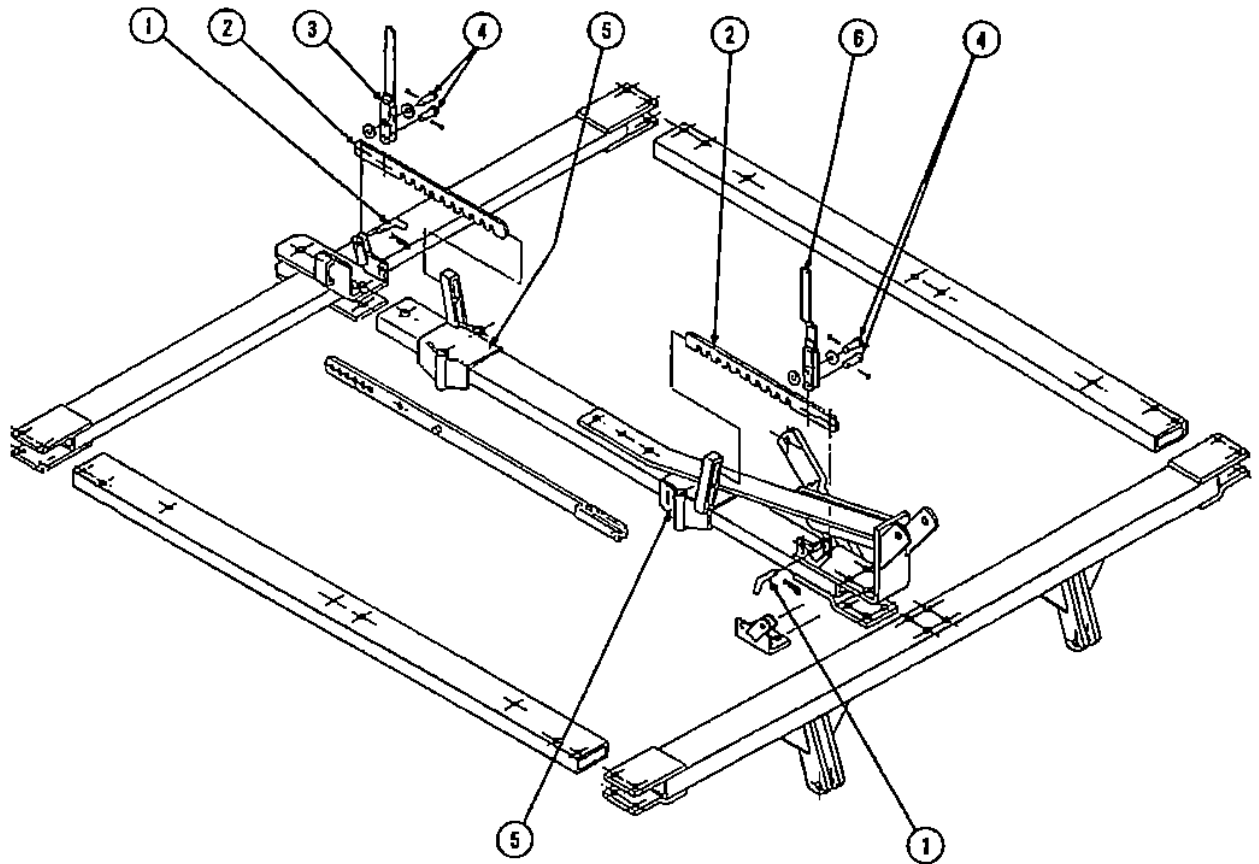

FIG. 3 — CENTER FRAME ASSEMBLY
WITH RATCHET TYPE, DISC GANG ANGLING CHANGE

Item No.	Part No.	PARTS LIST FOR WHEEL MOUNTED TANDEM MODELS																Description	Size		
		200108	200109	200110	200119	200100	200101	200111	200112	200113	200120	200102	200103	200114	200115	200116	200121			200117	200118
1.	209430	2	2	2	2	2	2	2	2	2	2	2	2	2	2	2	2	2	2	Gang Lock Pin	
	205829	2	2	2	2	2	2	2	2	2	2	2	2	2	2	2	2	2	2	Hitch Pin Clip	
2.	209433	2	2	2	2	0	0	2	2	2	2	0	0	2	2	2	2	0	0	Gang Ratchet Bar	
	209434	0	0	0	0	2	2	0	0	0	0	2	2	0	0	0	0	2	2	Fl. & Fr. Gang Ratchet Bar	
3.	209420	2	2	2	2	1	1	2	2	2	2	1	1	2	2	2	2	1	1	Rear Adjustment Handle	
4.	209431	4	4	4	4	4	4	4	4	4	4	4	4	4	4	4	4	4	4	Button Head Rivet	1/2" x 2"
		4	4	4	4	4	4	4	4	4	4	4	4	4	4	4	4	4	4	Flat Washer	1/2"
		4	4	4	4	4	4	4	4	4	4	4	4	4	4	4	4	4	4	Cotter	5/32" x 1 1/4"
5.	209273	2	2	2	2	2	2	2	2	2	2	2	2	2	2	2	2	2	2	Angling Slide	
		6.	209417	0	0	0	0	1	1	0	0	0	0	1	1	0	0	0	1	1	Front Adjustment Handle

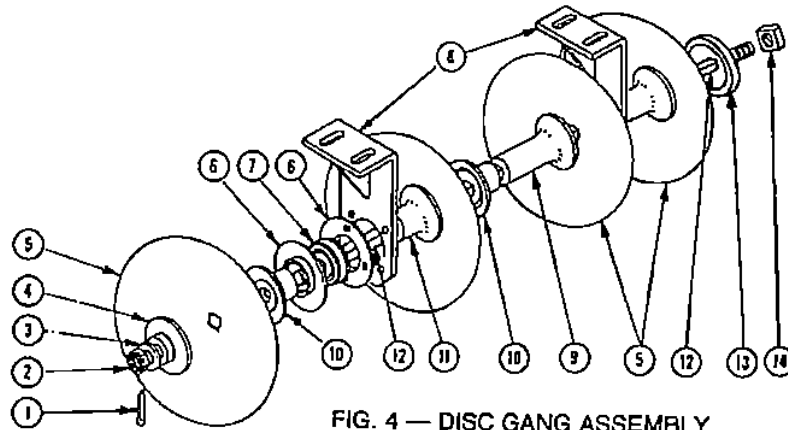

FIG. 4 — DISC GANG ASSEMBLY

Item No.	Part No.	PARTS LIST FOR WHEEL MOUNTED TANDEM MODELS																Description	Size		
		200108	200109	200110	200119	200100	200101	200111	200112	200113	200120	200102	200103	200114	200115	200116	200121			200117	200118
1.		4	4	4	8	8	8	4	4	4	8	8	8	4	4	4	8	8	8	Cotter	3/16" x 2"
2.		4	4	4	8	8	8	4	4	4	8	8	8	4	4	4	8	8	8	Slotted Hex Nut	1 1/2"
3.		4	4	4	8	8	8	4	4	4	8	8	8	4	4	4	8	8	8	Flat Washer	1 1/4"
4.	204704	4	4	4	8	8	8	4	4	4	8	8	8	4	4	4	8	8	8	End Washer	
5.	205003	16	20	24	28	32	36	20	24	28	32	40	44	18	22	26	30	36	40	18" Plain Round Disc	
	205002	16	20	24	28	32	36	20	24	28	32	40	44	18	22	26	30	36	40	18" Cut-Out Disc	
	204004	12	16	20	24	28	32	16	20	24	28	36	40	14	18	22	26	32	36	20" Plain Round Disc	
	204003	12	16	20	24	28	32	16	20	24	28	36	40	14	18	22	26	32	36	20" Cut-Out Disc	
	204010	12	16	20	24	28	32	16	20	24	28	36	40	14	18	22	26	32	36	22" Plain Round Disc	
	205020	12	16	20	24	28	32	16	20	24	28	36	40	14	18	22	26	32	36	22" Cut-Out Disc	
	204005	12	16	20	24	28	32	16	20	24	28	36	40	14	18	22	26	32	36	22" Plain Round Disc, Heavy-Duty	
	205005	12	16	20	24	28	32	16	20	24	28	36	40	14	18	22	26	32	36	22" Cut-Out Disc	
	205006	12	16	20	24	28	32	16	20	24	28	36	40	14	18	22	26	32	36	22" Cut-Out Disc, Heavy-Duty	
	203303	12	16	20	24	28	32	16	20	24	28	36	40	14	18	22	26	32	36	24" Plain Round Disc	
	205004	12	16	20	24	28	32	16	20	24	28	36	40	14	18	22	26	32	36	24" Cut-Out Disc, Heavy-Duty	
																				TAPERED DISC BLADES FOR HARROWS EQUIPPED WITH 20" DISC BLADES.	
	205003	4	4	4	4	4	4	4	4	4	4	4	4	4	4	4	4	4	4	18" Plain Round Disc	
	205002	4	4	4	4	4	4	4	4	4	4	4	4	4	4	4	4	4	4	18" Cut-Out Disc	
																				TAPERED DISC BLADES FOR HARROWS EQUIPPED WITH 22" DISC BLADES.	
	204004	4	4	4	4	4	4	4	4	4	4	4	4	4	4	4	4	4	4	20" Plain Round Disc	
	204003	4	4	4	4	4	4	4	4	4	4	4	4	4	4	4	4	4	4	20" Cut-Out Disc	
																				TAPERED DISC BLADES FOR HARROWS EQUIPPED WITH 24" DISC BLADES.	
	204010	4	4	4	4	4	4	4	4	4	4	4	4	4	4	4	4	4	4	22" Plain Round Disc	
	205020	4	4	4	4	4	4	4	4	4	4	4	4	4	4	4	4	4	4	22" Plain Round Disc, Heavy-Duty	
	204005	4	4	4	4	4	4	4	4	4	4	4	4	4	4	4	4	4	4	22" Cut-Out Disc	
	205005	4	4	4	4	4	4	4	4	4	4	4	4	4	4	4	4	4	4	22" Cut-Out Disc, Heavy-Duty	
6.	204148	16	16	16	32	32	32	16	16	16	32	32	32	16	16	18	32	32	32	Flange, Standard	
	207381	8	8	8	16	16	16	8	8	8	16	16	16	8	8	8	16	16	16	Flange, Retube, Plain	
	207380	8	8	8	16	16	16	8	8	8	16	16	16	8	8	8	16	16	16	Flange, Retube With Alomite	
7.	204147	8	8	8	16	16	16	8	8	8	16	16	16	8	8	8	16	16	16	Bolt W/Nut	1/2" x 1 1/4"
	207359	8	8	8	16	16	16	8	8	8	16	16	16	8	8	8	16	16	16	Bearing, Standard	
8.	205030	8	8	8	16	16	16	8	8	8	16	16	16	8	8	8	16	16	16	Bearing, Retube	
		16	16	16	32	32	32	16	16	16	32	32	32	16	16	16	32	32	32	Flange Holder	
		16	16	16	32	32	32	16	16	16	32	32	32	16	16	16	32	32	32	Bolt W/Nut	3/4" x 2"
		16	16	16	32	32	32	16	16	16	32	32	32	16	16	16	32	32	32	Lock Washer	3/4"
9.	200825	4	8	12	4	8	12	0	0	0	0	0	0	2	4	6	2	4	6	Flat Washer	3/4"
																				Long Convex Spacer for 9" Disc Spacing	
	205488	0	0	0	0	0	0	8	12	16	8	16	20	4	6	8	4	8	10	Long Convex Spacer for 7 1/2" Disc Spacing	
10.	205486	12	16	20	20	24	28	16	20	24	24	32	36	14	18	22	22	28	32	Concave Spacer for 7 1/2" or 9" Disc Spacing	
11.	206826	8	8	8	16	16	16	0	0	0	0	0	0	4	4	4	8	8	8	Short Convex Spacer for 9" Disc Spacing	
	205489	0	0	0	0	0	0	8	8	8	16	16	16	4	4	4	8	8	8	Short Convex Spacer for 7 1/2" Disc Spacing	
12.	206621	0	0	0	4	0	0	0	0	0	0	0	0	0	0	0	2	0	0	3-Disc Axle, 9" Disc Spacing, 22 7/8"	
	206626	4	0	0	4	8	4	0	0	0	0	0	0	0	2	0	0	0	0	4-Disc Axle, 9" Disc Spacing, 32-1/16"	
	206627	0	4	0	0	0	4	0	0	0	0	0	0	0	0	0	0	0	0	5-Disc Axle, 9" Disc Spacing, 41-1/16"	
	206618	0	0	4	0	0	0	0	0	0	0	0	0	0	0	2	0	0	0	6-Disc Axle, 9" Disc Spacing, 50 1/4"	
	206615	0	0	0	0	0	0	0	0	0	0	0	0	0	0	0	0	0	0	4-Disc Axle, 7 1/2" Disc Spacing, 27-7/16"	
	207038	0	0	0	0	0	0	4	0	0	0	0	0	8	4	2	0	0	0	5-Disc Axle, 7 1/2" Disc Spacing, 35-1/16"	
	207039	0	0	0	0	0	0	0	0	4	0	0	0	0	0	2	0	0	0	6-Disc Axle, 7 1/2" Disc Spacing, 42-15/16"	
	206618	0	0	0	0	0	0	0	0	0	0	0	0	0	0	0	0	0	0	7-Disc Axle, 7 1/2" Disc Spacing, 50 1/4"	
	206613	4	4	4	8	8	8	4	4	4	8	8	8	4	4	4	8	8	8	Built-Plate	
14.		4	4	4	8	8	8	4	4	4	8	8	8	4	4	4	8	8	8	Square Head Nut, 1 1/2"	

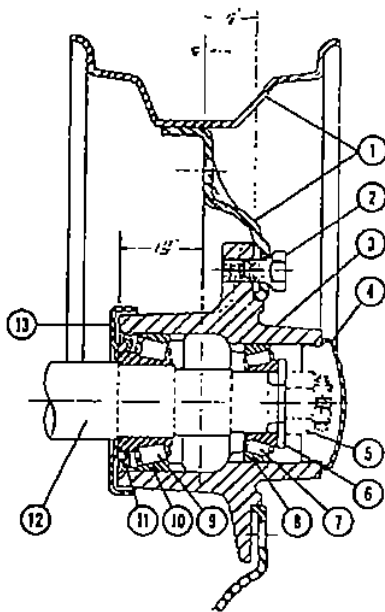
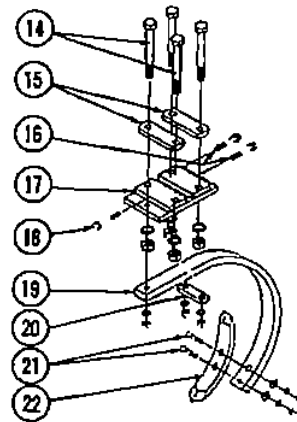

FIG. 5 — WHEEL HUB ASSEMBLY
SEE ITEM 17



BALK BREAKER ATTACHMENT
MACH. NO. 299054
REPAIRS ONLY

Item No.	Part No.	PARTS LIST FOR WHEEL MOUNTED TANDEM MODELS														Description	Size					
		200108	200109	200110	200119	200100	200101	200111	200112	200113	200120	200102	200103	200114	200115			200116	200121	200117	200118	
1.	208634	2	2	2	2	2	2	2	2	2	2	2	2	2	2	2	2	2	2	15" x 6" Wheel for Rubber		
2.	403817	12	12	12	12	12	12	12	12	12	12	12	12	12	12	12	12	12	12	Lug Bolt		
3.	204515	0	0	0	0	0	0	0	0	0	0	0	0	0	0	0	0	0	0	Wheel Hub with Two Cups		
NLA →	403829	0	0	0	0	0	0	0	0	0	0	0	0	0	0	0	0	0	0	Wheel Hub with Two Cups		
4.	204523	0	0	0	0	0	0	0	0	0	0	0	0	0	0	0	0	0	0	Hub Cap		
NLA →	403816	0	0	0	0	0	0	0	0	0	0	0	0	0	0	0	0	0	0	Hub Cap		
5.	204522	0	0	0	0	0	0	0	0	0	0	0	0	0	0	0	0	0	0	Bearing Adjustment Nut		
	403853	0	0	0	0	0	0	0	0	0	0	0	0	0	0	0	0	0	0	Bearing Adjustment Nut		
6.	204521	0	0	0	0	0	0	0	0	0	0	0	0	0	0	0	0	0	0	Cotter	5/32" x 1 1/4"	
7.	204524	0	0	0	0	0	0	0	0	0	0	0	0	0	0	0	0	0	0	Special Flat Washer		
NLA →	403813	0	0	0	0	0	0	0	0	0	0	0	0	0	0	0	0	0	0	Cone		
8.	203021	0	0	0	0	0	0	0	0	0	0	0	0	0	0	0	0	0	0	Cone		
NLA →	403814	0	0	0	0	0	0	0	0	0	0	0	0	0	0	0	0	0	0	Cup		
9.	204526	0	0	0	0	0	0	0	0	0	0	0	0	0	0	0	0	0	0	Cup		
NLA →	403812	0	0	0	0	0	0	0	0	0	0	0	0	0	0	0	0	0	0	Cone		
10.	204525	0	0	0	0	0	0	0	0	0	0	0	0	0	0	0	0	0	0	Cone		
	203021	0	0	0	0	0	0	0	0	0	0	0	0	0	0	0	0	0	0	Cup		
11.	204527	0	0	0	0	0	0	0	0	0	0	0	0	0	0	0	0	0	0	Cup		
NLA →	403815	0	0	0	0	0	0	0	0	0	0	0	0	0	0	0	0	0	0	Grease Seal		
12.	205033	0	0	0	0	1	1	0	0	0	0	0	0	0	0	0	0	0	0	0	Grease Seal	
	205180	1	1	1	1	0	0	1	1	1	1	1	1	1	1	1	1	1	1	0	Wheel Lift	
	206441	0	0	0	0	1	1	0	0	0	0	0	0	0	0	0	0	0	0	0	Wheel Lift	
	204516	0	0	0	0	2	2	0	0	0	0	0	0	0	0	0	0	0	0	2	Wheel Lift for Dual Wheels	
	203773	2	2	2	2	0	0	2	2	2	2	0	0	2	2	2	2	0	0	0	Stub Axle (Sub Assembly) To Replace Worn Axle In Wheel Lift, Part No. 205033	
13.	204520	0	0	0	0	2	2	0	0	0	0	2	2	0	0	0	0	0	0	2	Stub Axle (Sub Assembly) To Replace Worn Axle In Wheel Lift, Part No. 205180	
	203811	2	2	2	2	0	0	2	2	2	2	0	0	2	2	2	2	2	2	2	Dust Collar	
14.		4	4	4	4	4	4	4	4	4	4	4	4	4	4	4	4	4	4	4	Dust Collar	
		4	4	4	4	4	4	4	4	4	4	4	4	4	4	4	4	4	4	4	Bolt W/Nut	3/4" x 5"
15.	603710	2	2	2	2	2	2	2	2	2	2	2	2	2	2	2	2	2	2	2	Lock Washer	3/4"
16.		2	2	2	2	2	2	2	2	2	2	2	2	2	2	2	2	2	2	2	Support Strap	
		2	2	2	2	2	2	2	2	2	2	2	2	2	2	2	2	2	2	2	Bolt W/Nut	5/8" x 3"
17.	207785	1	1	1	1	1	1	1	1	1	1	1	1	1	1	1	1	1	1	1	Lock Washer	5/8"
18.		1	1	1	1	1	1	1	1	1	1	1	1	1	1	1	1	1	1	1	Shank Connector Assy.	
		1	1	1	1	1	1	1	1	1	1	1	1	1	1	1	1	1	1	1	Bolt W/Nut	5/8" x 2 1/2"
19.	206726	1	1	1	1	1	1	1	1	1	1	1	1	1	1	1	1	1	1	1	Lock Washer	5/8"
20.	603710	1	1	1	1	1	1	1	1	1	1	1	1	1	1	1	1	1	1	1	22" Shank	
21.		2	2	2	2	2	2	2	2	2	2	2	2	2	2	2	2	2	2	2	Support Strap	
		2	2	2	2	2	2	2	2	2	2	2	2	2	2	2	2	2	2	2	Plow Bolt W/Nut	7/16" x 2 1/4"
		2	2	2	2	2	2	2	2	2	2	2	2	2	2	2	2	2	2	2	Lock Washer	7/16"
22.	603014	1	1	1	1	1	1	1	1	1	1	1	1	1	1	1	1	1	1	1	Flat Washer	7/16"
		1	1	1	1	1	1	1	1	1	1	1	1	1	1	1	1	1	1	1	Chisel	5/8"

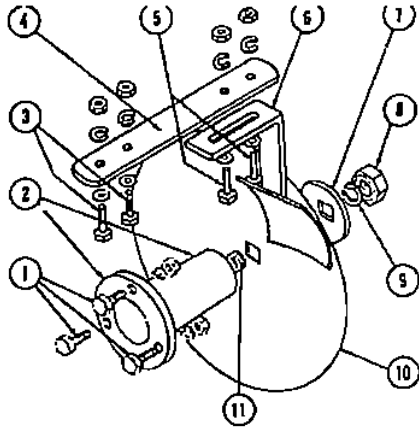

FIG. 6 — FURROW FILLER ATTACHMENT
MACH. NO. 200080

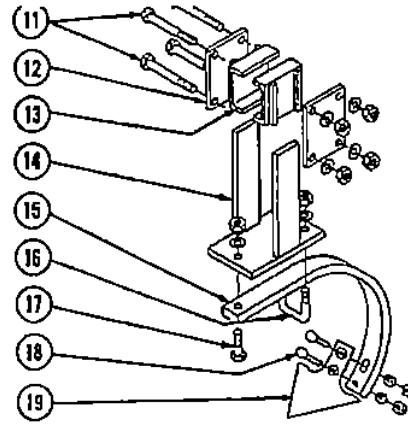

FIG. 7 — BALK BREAKER ATTACHMENT
MACH. NO. 299089

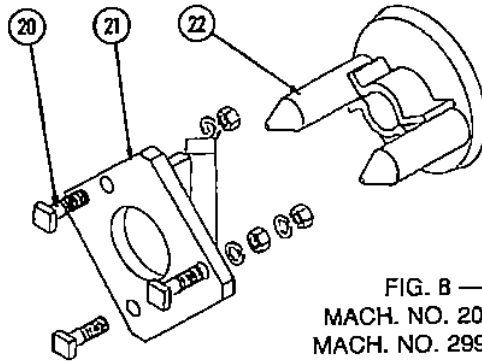

FIG. 8 — GANG COUPLER
MACH. NO. 200092 FOR 9" SPACING
MACH. NO. 299124 FOR 7½" SPACING

Aem No.	Part No.	PARTS LIST FOR WHEEL MOUNTED TANDEM MODELS																Description	Size		
		200108	200109	200110	200119	200100	200101	200111	200112	200113	200120	200102	200103	200114	200115	200116	200121			200117	200118
1.		6	6	6	6	6	6	6	6	6	6	6	6	6	6	6	6	6	6	Bolt W/Nut	½" x 1½"
2.	206829	2	2	2	2	2	2	2	2	2	2	2	2	2	2	2	2	2	2	Lock Washer	½"
3.		4	4	4	4	4	4	4	4	4	4	4	4	4	4	4	4	4	4	Furrow Filler Spacer	
4.	206797	2	2	2	2	2	2	2	2	2	2	2	2	2	2	2	2	2	2	Bolt W/Nut	½" x 2"
5.		4	4	4	4	4	4	4	4	4	4	4	4	4	4	4	4	4	4	Flat Washer	½"
6.	204909	1	1	1	1	1	1	1	1	1	1	1	1	1	1	1	1	1	1	Lock Washer	½"
7.	204911	1	1	1	1	1	1	1	1	1	1	1	1	1	1	1	1	1	1	Furrow Filler Scraper Bar	
8.	203986	2	2	2	2	2	2	2	2	2	2	2	2	2	2	2	2	2	2	Bolt W/Nut	½" x 1½"
9.		2	2	2	2	2	2	2	2	2	2	2	2	2	2	2	2	2	2	Flat Washer	½"
10.	204000	2	2	2	2	2	2	2	2	2	2	2	2	2	2	2	2	2	2	Lock Washer	½"
11.	204001	4	4	4	4	4	4	4	4	4	4	4	4	4	4	4	4	4	4	Right Scraper (for Left Rear)	
12.	303957	4	4	4	4	4	4	4	4	4	4	4	4	4	4	4	4	4	4	Left Scraper (for Right Rear)	
13.	304008	4	4	4	4	4	4	4	4	4	4	4	4	4	4	4	4	4	4	Furrow Filler Butt Plate	
14.	303956	2	2	2	2	2	2	2	2	2	2	2	2	2	2	2	2	2	2	Hex Nut	½"
15.	209637	2	2	2	2	2	2	2	2	2	2	2	2	2	2	2	2	2	2	Lock Washer	½"
16.	209633	1	1	1	1	1	1	1	1	1	1	1	1	1	1	1	1	1	1	18" Round Disc	
17.	207494	1	1	1	1	1	1	1	1	1	1	1	1	1	1	1	1	1	1	18" Round Disc	
18.	603954	2	2	2	2	2	2	2	2	2	2	2	2	2	2	2	2	2	2	Bolt	¾" x 7"
19.	304008	2	2	2	2	2	2	2	2	2	2	2	2	2	2	2	2	2	2	Nut	¾"
20.	303956	2	2	2	2	2	2	2	2	2	2	2	2	2	2	2	2	2	2	Lock Washer	½"
21.	303387	1	1	1	1	1	1	1	1	1	1	1	1	1	1	1	1	1	1	Connector Plate	¾"
22.	304008	1	1	1	1	1	1	1	1	1	1	1	1	1	1	1	1	1	1	Cuff	
23.	303956	2	2	2	2	2	2	2	2	2	2	2	2	2	2	2	2	2	2	Shank Connector	
24.	304008	1	1	1	1	1	1	1	1	1	1	1	1	1	1	1	1	1	1	16" Shank	
25.	303956	2	2	2	2	2	2	2	2	2	2	2	2	2	2	2	2	2	2	U-Bolt	¾"
26.	303387	1	1	1	1	1	1	1	1	1	1	1	1	1	1	1	1	1	1	Nut	¾"
27.	304008	1	1	1	1	1	1	1	1	1	1	1	1	1	1	1	1	1	1	Lock Washer	½"
28.	303956	1	1	1	1	1	1	1	1	1	1	1	1	1	1	1	1	1	1	Bolt	¾" x 2½"
29.	303344	2	2	2	2	2	2	2	2	2	2	2	2	2	2	2	2	2	2	Nut	¾"
30.	304006	2	2	2	2	2	2	2	2	2	2	2	2	2	2	2	2	2	2	Lock Washer	½"
31.	303954	2	2	2	2	2	2	2	2	2	2	2	2	2	2	2	2	2	2	Plow Bolt	7/8" x 1½"
32.	303970	2	2	2	2	2	2	2	2	2	2	2	2	2	2	2	2	2	2	Nut	7/8"
33.	209408	1	1	1	1	1	1	1	1	1	1	1	1	1	1	1	1	1	1	Lock Washer	7/8"
34.	303903	0	0	0	0	0	0	0	0	0	0	0	0	0	0	0	0	0	0	Flat Washer	7/8"
35.	303955	0	0	0	0	0	0	0	0	0	0	0	0	0	0	0	0	0	0	B" Sweep	
36.	207307	0	0	0	0	0	0	0	0	0	0	0	0	0	0	0	0	0	0	Bolt W/Nut	½" x 1½"
37.	210657	0	0	0	0	0	0	0	0	0	0	0	0	0	0	0	0	0	0	Lock Washer	½"
38.	207315	0	0	0	0	0	0	0	0	0	0	0	0	0	0	0	0	0	0	Butt Plate Drive, 8" Spacing	
39.	210659	0	0	0	0	0	0	0	0	0	0	0	0	0	0	0	0	0	0	Butt Plate Drive, 7½" Spacing	
40.		0	0	0	0	0	0	0	0	0	0	0	0	0	0	0	0	0	0	End Washer Drive, 9" Spacing	
41.		0	0	0	0	0	0	0	0	0	0	0	0	0	0	0	0	0	0	End Washer Drive, 7½" Spacing	

SETTING-UP INSTRUCTIONS

FOR

TAYLOR-WAY

WHEEL MOUNTED TANDEM HARROWS

General

Right and left are determined by standing at the rear of the harrow. All items designated as right and left fit into their respective positions on the front section. When used on the rear section, the procedure is reversed and items designated as right will fit onto the left side and vice versa. These harrows are shipped "Knocked Down" and are bundled into the bundles listed below:

Bundle Number	Bundles Required																		Description
	200 108	200 109	200 110	200 119	200 100	200 101	200 111	200 112	200 113	200 120	200 102	200 103	200 114	200 115	200 116	200 121	200 117	200 118	
200729	1	1	1	1	0	0	1	1	1	1	0	0	1	1	1	1	0	0	Tongue Bundle
200707	0	0	0	0	1	1	0	0	0	0	1	1	0	0	0	0	1	1	Tongue Bundle
200710	0	0	0	0	1	1	0	0	0	0	1	1	0	0	0	0	1	1	Center Frame Assembly
200730	1	1	1	1	0	0	1	1	1	1	0	0	1	1	1	1	0	0	Front & Rear Cross Frames
200708	0	0	0	0	1	1	0	0	0	0	1	1	0	0	0	0	1	1	Front & Rear Cross Frames
200709	1	1	1	1	1	1	1	1	1	1	1	1	1	1	1	1	1	1	Right and Left Side Frames
200733	1	1	1	1	0	0	1	1	1	1	0	0	1	1	1	1	0	0	Single Wheel Lift Assembly
200711	0	0	0	0	1	1	0	0	0	0	1	1	0	0	0	0	1	1	Single Wheel Lift Assy
200712	0	0	0	0	1	1	0	0	0	0	1	1	0	0	0	0	1	1	Dual Wheel Lift Assy.*
201969	1	1	1	1	0	0	1	1	1	1	0	0	1	1	1	1	0	0	Dual Wheel Lift Assy.*
201449	2/4	2/4	2/4	2/4	2/4	2/4	2/4	2/4	2/4	2/4	2/4	2/4	2/4	2/4	2/4	2/4	2/4	2/4	15' x 6" Flms
200721	0	0	0	0	0	0	0	0	0	0	1	0	0	0	0	0	0	0	Right Front Gang Frame
200722	0	0	0	0	0	0	0	0	0	0	1	0	0	0	0	0	0	0	Left Front Gang Frame
200723	0	0	0	0	0	0	0	0	0	0	1	0	0	0	0	0	1	0	Right Rear Gang Frame
200724	0	0	0	0	0	0	0	0	0	0	1	0	0	0	0	0	1	0	Left Rear Gang Frame
200725	0	0	0	0	0	0	0	0	0	0	0	1	0	0	0	0	0	0	Right Front Gang Frame
200726	0	0	0	0	0	0	0	0	0	0	0	1	0	0	0	0	0	0	Left Front Gang Frame
200727	0	0	0	0	0	0	0	0	0	0	0	1	0	0	0	0	0	1	Right Rear Gang Frame
200728	0	0	0	0	0	0	0	0	0	0	0	1	0	0	0	0	0	1	Left Rear Gang Frame
200717	0	0	0	0	0	1	0	0	0	0	0	0	0	0	0	0	0	1	Right Front Gang Frame
200718	0	0	0	0	0	1	0	0	0	0	0	0	0	0	0	0	0	1	Left Front Gang Frame
200719	0	0	0	0	0	1	0	0	0	0	0	0	0	0	0	0	0	0	Right Rear Gang Frame
200720	0	0	0	0	0	1	0	0	0	0	0	0	0	0	0	0	0	0	Left Rear Gang Frame
200751	0	0	0	0	0	0	1	0	0	0	0	0	0	0	0	0	0	0	Right Front Gang Frame
200752	0	0	0	0	0	0	1	0	0	0	0	0	0	0	0	0	0	0	Left Front Gang Frame
200753	0	0	0	0	0	0	1	0	0	0	0	0	1	0	0	0	0	0	Right Rear Gang Frame
200754	0	0	0	0	0	0	1	0	0	0	0	0	1	0	0	0	0	0	Left Rear Gang Frame
200755	0	0	0	0	0	0	0	1	0	0	0	0	0	0	0	0	0	0	Right Front Gang Frame
200756	0	0	0	0	0	0	0	1	0	0	0	0	0	0	0	0	0	0	Left Front Gang Frame
200757	0	0	0	0	0	0	0	1	0	0	0	0	0	1	0	0	0	0	Right Rear Gang Frame
200758	0	0	0	0	0	0	0	1	0	0	0	0	0	1	0	0	0	0	Left Rear Gang Frame
200759	0	0	0	0	0	0	0	0	1	0	0	0	0	0	0	0	0	0	Right Front Gang Frame
200760	0	0	0	0	0	0	0	0	1	0	0	0	0	0	0	0	0	0	Left Front Gang Frame
200761	0	0	0	0	0	0	0	0	1	0	0	0	0	0	1	0	0	0	Right Rear Gang Frame
200762	0	0	0	0	0	0	0	0	1	0	0	0	0	0	1	0	0	0	Left Rear Gang Frame

Bundle Number	Bundles Required																		Description	
	200 109	200 109	200 110	200 119	200 100	200 101	200 111	200 112	200 113	200 120	200 102	200 103	200 114	200 115	200 116	200 121	200 117	200 118		
200763	0	0	0	0	0	0	0	0	0	0	1	0	0	0	0	0	0	0	0	Right Front Gang Frame
200764	0	0	0	0	0	0	0	0	0	0	1	0	0	0	0	0	0	0	0	Left Front Gang Frame
200765	0	0	0	0	0	0	0	0	0	0	1	0	0	0	0	0	1	0	0	Right Rear Gang Frame
200768	0	0	0	0	0	0	0	0	0	0	1	0	0	0	0	0	1	0	0	Left Rear Gang Frame
200735	1	0	0	0	0	0	0	0	0	0	0	0	0	1	0	0	0	0	0	Right Front Gang Frame
200736	1	0	0	0	0	0	0	0	0	0	0	0	0	1	0	0	0	0	0	Left Front Gang Frame
200737	1	0	0	0	0	0	0	0	0	0	0	0	0	0	0	0	0	0	0	Right Rear Gang Frame
200738	1	0	0	0	0	0	0	0	0	0	0	0	0	0	0	0	0	0	0	Left Rear Gang Frame
200739	0	1	0	0	0	0	0	0	0	0	0	0	0	0	1	0	0	0	0	Right Front Gang Frame
200740	0	1	0	0	0	0	0	0	0	0	0	0	0	0	1	0	0	0	0	Left Front Gang Frame
200741	0	1	0	0	0	0	0	0	0	0	0	0	0	0	0	0	0	0	0	Right Rear Gang Frame
200742	0	1	0	0	0	0	0	0	0	0	0	0	0	0	0	0	0	0	0	Left Rear Gang Frame
200743	0	0	1	0	0	0	0	0	0	0	0	0	0	0	0	1	0	0	0	Right Front Gang Frame
200744	0	0	1	0	0	0	0	0	0	0	0	0	0	0	0	1	0	0	0	Left Front Gang Frame
200745	0	0	1	0	0	0	0	0	0	0	0	0	0	0	0	0	0	0	0	Right Rear Gang Frame
200746	0	0	1	0	0	0	0	0	0	0	0	0	0	0	0	0	0	0	0	Left Rear Gang Frame
200747	0	0	0	1	0	0	0	0	0	0	0	0	0	0	0	0	1	0	0	Right Front Gang Frame
200748	0	0	0	1	0	0	0	0	0	0	0	0	0	0	0	0	1	0	0	Left Front Gang Frame
200749	0	0	0	1	0	0	0	0	0	0	0	0	0	0	0	0	0	0	0	Right Rear Gang Frame
200750	0	0	0	1	0	0	0	0	0	0	0	0	0	0	0	0	0	0	0	Left Rear Gang Frame
200713	0	0	0	0	1	0	0	0	0	0	0	0	0	0	0	0	0	1	0	Right Front Gang Frame
200714	0	0	0	0	1	0	0	0	0	0	0	0	0	0	0	0	0	1	0	Left Front Gang Frame
200715	0	0	0	0	1	0	0	0	0	0	0	0	0	0	0	0	0	0	0	Right Rear Gang Frame
200716	0	0	0	0	1	0	0	0	0	0	0	0	0	0	0	0	0	0	0	Left Rear Gang Frame
TOTAL	11/13	11/13	11/13	11/13	11/13	11/13	11/13	11/13	11/13	11/13	11/13	11/13	11/13	11/13	11/13	11/13	11/13	11/13	11/13	

EXTRA EQUIPMENT

* Denotes Optional Wheel Lift Assy's.

Machinery No. 200080 — Furrow Filler Attachment, less Disc.
 Furrow Filler Attachment w/16" Round Disc.
 Furrow Filler Attachment w/18" Round Disc.

Machinery No. 289089 — Balk Breaker Attachment.

Machinery No. 200092 — Gang Connector, used to connect split gangs together, one connector required for each set of gangs connected. When shipped assembled on implement, these are included in disc gang bundle. For 9" Spacing.

Machinery No. 289124 — Gang Connector For 7½" Spacing.

Bundle Number	Bundles Required				Bundles Shipped	Description
	200 080	289 054	200 092	289 124		
201048	1	0	0	0		Furrow Filler Attachment, less Discs*
201049	1	0	0	0		Furrow Filler Attachment w/Two 16" Round Discs*
201050	1	0	0	0		Furrow Filler Attachment w/Two 18" Round Discs*
	1	0	0	0		Scrapers for Furrow Filler (optional)
201958	0	1	0	0		Balk Breaker Attachment
201051	0	0	1	0		Gang Connector, 9" Spacing
202417	0	0	0	1		Gang Connector, 7½" Spacing
TOTAL	1 or 2	1	1	1		

* Denotes Options on furrow filler attachment.