

Taylor-Way

REG. U. S. PAT. OFF.

PARTS LIST

Setting-up and Operating Instructions for PULVERIZING HYDRAULIC FOLDING FLEXIBLE WHEEL TANDEM HARROW

20" OR 22" DISC

REGREASEABLE BALL BEARINGS

8" DISC SPACING

1 1/2" SQUARE AXLE

MODEL NUMBER	NO. OF DISC	SIZE OF WINGS	WIDTH OF CUT	NO. OF BEARINGS	APPROXIMATE WEIGHT		APPROXIMATE D.B.H.P.
					20" CUT OUT	22" CUT OUT	
STANDARD BEARING HANGERS — 12' 9" TRANSPORT WIDTH							
200051	54	5-Disc Front, 8-Disc Rear	17' 5"	18	5460	5645	100
200052	62	8-Disc Front, 10-Disc Rear	19' 11"	22	5935	6155	110
200053	70	10-Disc Front, 12-Disc Rear	22' 6"	24	6450	6685	125
200054	78	12-Disc Front, 14-Disc Rear	25' 0"	26	7050	7130	140
FLEXIBLE BEARING HANGERS — 12' 9" TRANSPORT WIDTH							
200051	54	6-Disc Front, 8-Disc Rear	17' 5"	18	5705	5890	100
200052	62	8-Disc Front, 10-Disc Rear	19' 11"	22	6205	6425	110
200053	70	10-Disc Front, 12-Disc Rear	22' 6"	24	6745	6990	125
200054	78	12-Disc Front, 14-Disc Rear	25' 0"	26	7370	7450	140

Above implements are shipped with extra disc on outside of each rear wing. The outside discs on front wings are tapered 2" and the outside two discs on rear wings are tapered 2" and 4". 17' 5", 19' 11", 23' 9" and 28' 3" sizes shipped with six 15" x 8" Rims. Other sizes are shipped with eight.

Tires and tubes not furnished. Use 9.5L x 15" Floation Tires. Shipped with two 4" x 24" double action Hydraulic Cylinders for wings and two 4" x 8" double action Hydraulic Cylinders for transport plus all hoses and fittings as Standard Equipment. Balk Breaker, Furrow Filler, and Gang Connectors available as Extra Equipment.

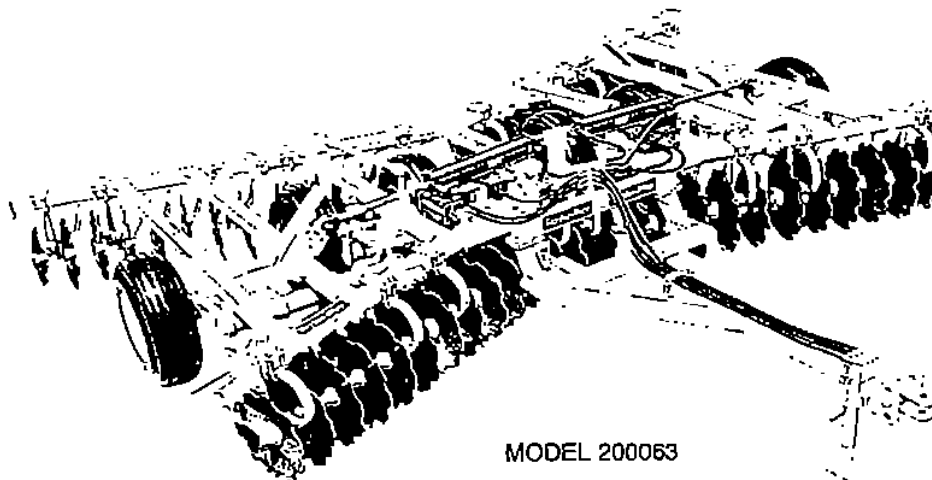

MODEL 200053

TAYLOR IMPLEMENT DIVISION

PITTSBURGH FORGINGS CO.

TRACTOR DRAWN *Taylor-Way* IMPLEMENTS

ATHENS, TENNESSEE 37303—TELEPHONE AREA CODE 615 745-3110

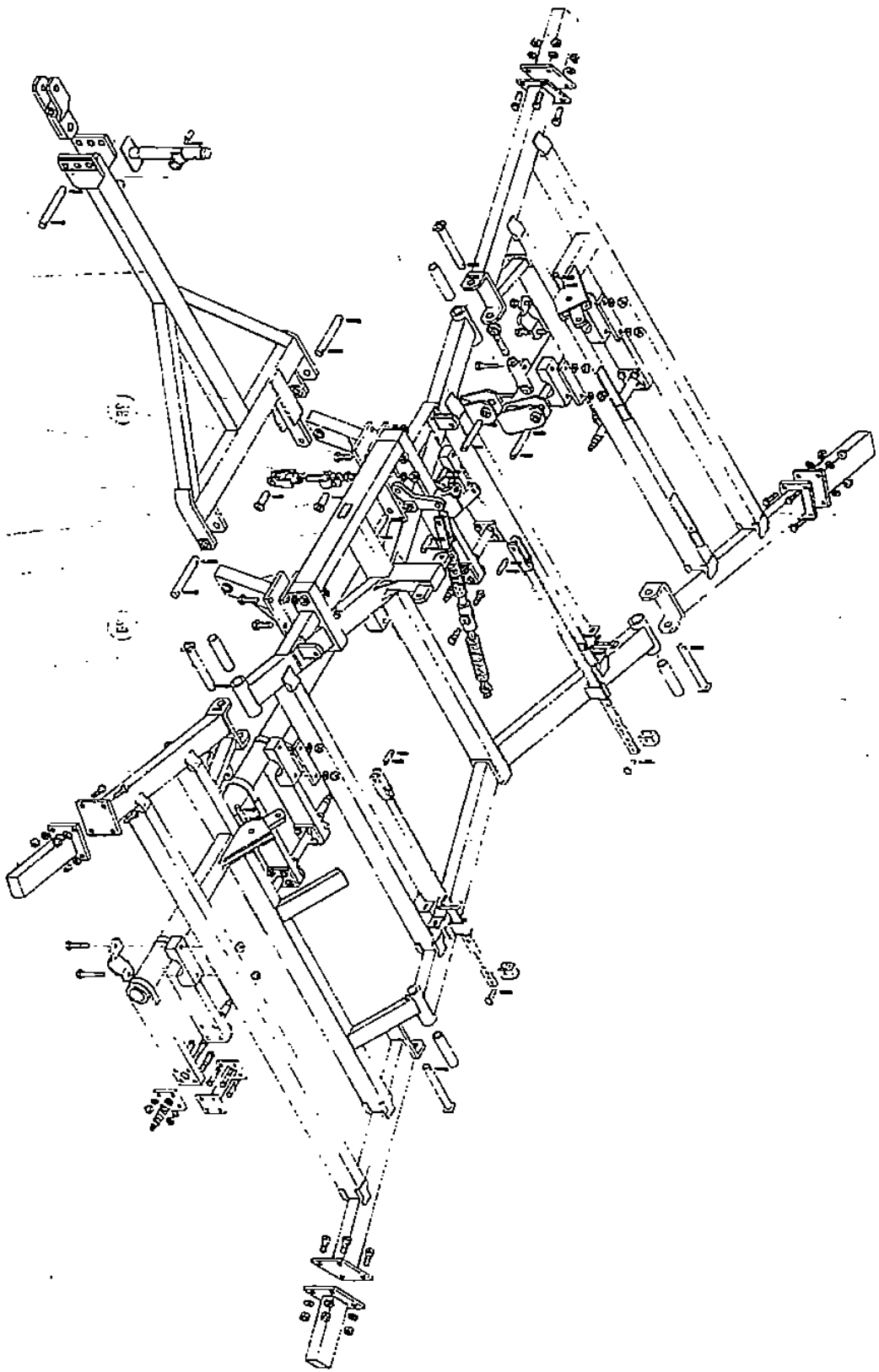

FIG. 1 — BASIC FRAME MODELS 200051-54; 200061-64

PARTS LIST FOR BASIC FRAME

(Refer to Index page 19 for Table of Contents)

Item No.	Part Number	FOR MODELS									Description	Size
		200 051	200 052	200 053	200 054	200 061	200 062	200 063	200 084			
1	209013	1	1	1	1	1	1	1	1	1	Single or Double Drawbar Clevis	
2	209186	1	1	1	1	1	1	1	1	1	Clevis Pin	1 3/8" x 9"
		2	2	2	2	2	2	2	2	2	Cotter	3/8" x 2"
3	208947	1	1	1	1	1	1	1	1	1	Tongue	
	208936	1	1	1	1	1	1	1	1	1	Tension Bushing	
4	209187	1	1	1	1	1	1	1	1	1	Leveling Adjustment Rod	
5	209190	1	1	1	1	1	1	1	1	1	Leveling Adjustment Housing	
6	209135	2	2	2	2	2	2	2	2	2	Tongue Conn. Pin	1 1/2" x 2 3/8"
		2	2	2	2	2	2	2	2	2	Cotter	3/8" x 2"
7	209127	1	1	1	1	1	1	1	1	1	Leveling Arm Pin	1 1/8" x 6 1/8"
		2	2	2	2	2	2	2	2	2	Cotter	3/8" x 2"
8	209125	2	2	2	2	2	2	2	2	2	Tongue Hinge Pin	1 3/8" x 8"
		4	4	4	4	4	4	4	4	4	Cotter	3/8" x 2"
9	209045	4	4	4	4	4	4	4	4	4	Bushing	
10	209128	4	4	4	4	4	4	4	4	4	Wing Hinge Pin	1 3/8" x 1 13/16"
		4	4	4	4	4	4	4	4	4	Cotter	3/8" x 2"
11	208995	1	1	0	0	1	1	0	0	0	Small Left Wing Frame	
	208997	0	0	1	1	0	0	1	1	1	Large Left Wing Frame	
12	209018	0	4	0	4	0	4	0	4	4	16" Extension Tube	
		0	16	0	16	0	16	0	16	0	Bolt w/Nut	3/4" x 2 1/4"
		0	16	0	16	0	16	0	16	0	Lock Washer	3/8"
13	207802	7	7	7	7	7	7	7	7	7	Wheel Axle Strap	
14	207801	7	7	7	7	7	7	7	7	7	Wheel Axle Bearing	
		7	7	7	7	7	7	7	7	7	Alemite	1/8"
		7	7	7	7	7	7	7	7	7	Bolt w/Nut	3/2" x 5"
		7	7	7	7	7	7	7	7	7	Bolt w/Nut	3/4" x 6"
		14	14	14	14	14	14	14	14	14	Lock Washer	3/8"
15	209054	1	1	0	0	1	1	0	0	0	Small Left Wheel Lift	
	209056	0	0	1	1	0	0	1	1	1	Large Left Wheel Lift	
16	209050	6	6	8	8	6	6	8	8	8	Wheel Axle	
	209049	2	2	0	0	2	2	0	0	0	Connector Plate (For Single Wheel Axle)	
17	209047	4	4	4	4	4	4	4	4	4	Wheel Axle Connector	
		32	32	32	32	32	32	32	32	32	Bolt w/Nut	3/4" x 4 1/2"
		32	32	32	32	32	32	32	32	32	Lock Washer	3/8"
18	209160	2	2	2	2	2	2	2	2	2	Wing Latch Pin	
	205829	2	2	2	2	2	2	2	2	2	Hitch Pin Clip	
19	203058	2	2	2	2	2	2	2	2	2	Depth Control Pin	
	205829	2	2	2	2	2	2	2	2	2	Hitch Pin Clip	
20	204683	2	2	2	2	2	2	2	2	2	Depth Control Cuff	
21	209251	2	2	2	2	2	2	2	2	2	Depth Control Bar	
	208092	2	2	2	2	2	2	2	2	2	Depth Bar Pin	1 3/8" x 3 3/8"
		4	4	4	4	4	4	4	4	4	Cotter	3/8" x 2"
22	208969	1	1	1	1	1	1	1	1	1	Center Frame	
	208863	4	4	4	4	4	4	4	4	4	Tension Bushing	
		4	4	4	4	4	4	4	4	4	Alemite	1/8"
23	209034	1	1	1	1	1	1	1	1	1	Wheel Lift	
24		1	1	1	1	1	1	1	1	1	Nut Plated	1 3/8"
	205163	2	2	2	2	2	2	2	2	2	Special Washer	1 3/8"
25	207894	2	2	2	2	2	2	2	2	2	Spring	
26	203742	1	1	1	1	1	1	1	1	1	Spring Rod Slide	
		1	1	1	1	1	1	1	1	1	Alemite	1/8"
	203748	2	2	2	2	2	2	2	2	2	Shoulder Bolt	
		2	2	2	2	2	2	2	2	2	Lock Washer	7/8"
27	209024	1	1	1	1	1	1	1	1	1	Spring Rod	
	208098	1	1	1	1	1	1	1	1	1	Spring Rod Pin	1 1/8" x 3 3/8"
		2	2	2	2	2	2	2	2	2	Cotter	3/8" x 2"
28	209022	1	1	1	1	1	1	1	1	1	Leveling Arm	
	208936	1	1	1	1	1	1	1	1	1	Tension Bushing	
29	209053	1	1	0	0	1	1	0	0	0	Small Right Wheel Lift	
	209055	0	0	1	1	0	0	1	1	1	Large Right Wheel Lift	
30	208994	1	1	0	0	1	1	0	0	0	Small Right Wing Frame	
	208996	0	0	1	1	0	0	1	1	1	Large Right Wing Frame	
31	209044	2	2	2	2	2	2	2	2	2	Wing Lift Arm	
	208863	4	4	4	4	4	4	4	4	4	Tension Bushing	
32	209126	2	2	2	2	2	2	2	2	2	Wing Flout Pin	1" x 3 1/2"
		4	4	4	4	4	4	4	4	4	Cotter	3/8" x 2"
33	208716	2	2	2	2	2	2	2	2	2	Wheel Adjustment Rod	
34	208714	2	2	2	2	2	2	2	2	2	Wheel Adjustment Connector	
		2	2	2	2	2	2	2	2	2	Alemite	1/8"
35	209119	4	4	4	4	4	4	4	4	4	Wheel Connector Pin	1 1/8" x 6 5/8"
		4	4	4	4	4	4	4	4	4	Cotter	3/8" x 2"
36	209043	2	2	2	2	2	2	2	2	2	Hydraulic Cylinder Brkt.	
	208863	4	4	4	4	4	4	4	4	4	Tension Bushing	
	209126	2	2	2	2	2	2	2	2	2	Hydraulic Cylinder Brkt. Pin	1" x 3 1/2"
		4	4	4	4	4	4	4	4	4	Cotter	3/8" x 2"
37	209199	1	1	1	1	1	1	1	1	1	Rt. Tongue Conn. Assy.	
38		8	8	8	8	8	8	8	8	8	Bolt w/Nut	3/8" x 2 1/2"
		8	8	8	8	8	8	8	8	8	Lock Washer	3/8"
39	209200	1	1	1	1	1	1	1	1	1	Lt. Tongue Conn. Assy.	
40	208867	1	1	1	1	1	1	1	1	1	Manual Jack	

Implements are shipped with extra disc on outside of each rear wing
 The outside discs on front wings are tapered 2" and the outside
 two discs on rear wings are tapered 2" and 4".

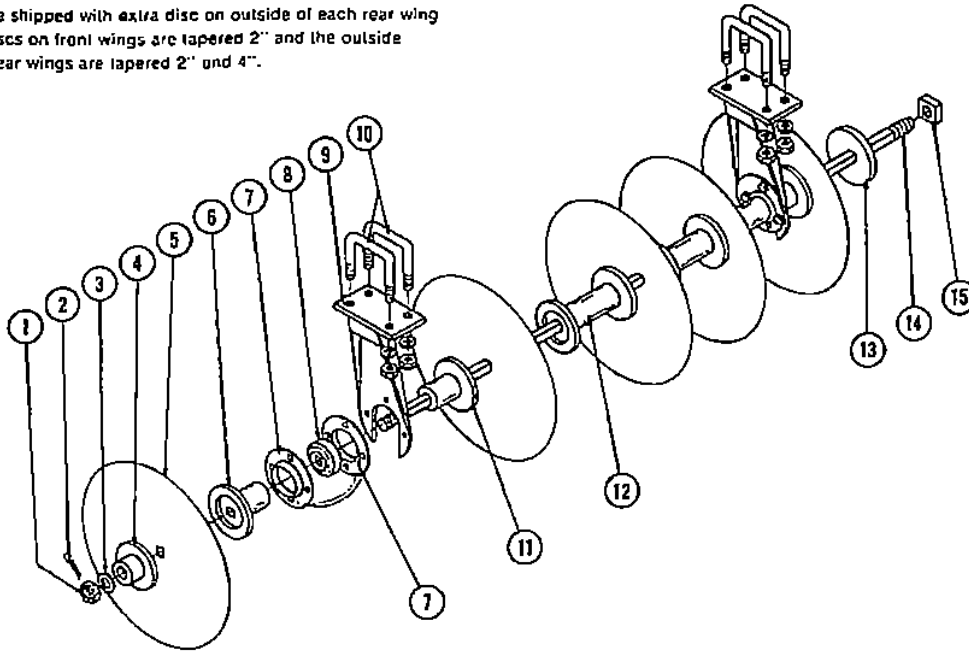

FIG. 2 — FLANGE BEARING CONNECTOR DISC GANG ASSEMBLY

Item No.	Part Number	FOR MODEL				Description	Size
		200051	200052	200053	200054		
1	304039	8	10	12	12	Hex Slotted Nut	1 1/8"
2	304111	8	10	12	12	Cotter	3/16" x 2"
3	303976	8	10	12	12	Flat Washer	1 1/8"
4	204701	8	10	12	12	End Washer	
5	208944	48	56	64	72	20" x 8 Ga. Round Disc	
	208946	4	4	4	4	18" x 8 Ga. Round Disc	
	208439	2	2	2	2	16" x 9 Ga. Round Disc	
	208943	48	56	64	72	20" x 8 Ga. Cut-Out Disc	
	208945	4	4	4	4	18" x 8 Ga. Cut-Out Disc	
	208440	2	2	2	2	16" x 9 Ga. Cut-Out Disc	
	208942	48	56	64	72	22" x 8 Ga. Round Disc	
	208944	4	4	4	4	20" x 8 Ga. Round Disc	
	208946	2	2	2	2	18" x 8 Ga. Round Disc	
	208941	48	56	64	72	22" x 8 Ga. Cut-Out Disc	
	208943	4	4	4	4	20" x 8 Ga. Cut-Out Disc	
	208945	2	2	2	2	18" x 8 Ga. Cut-Out Disc	
6	207341	18	22	24	26	Concave Spacer	
7	207361	18	22	24	26	Flange, Retube, Plain	
	207360	18	22	24	26	Flange, Retube, w/Alemite	
		72	88	96	104	Bolt w/Nut	1/2" x 1 1/4"
8	207359	18	22	24	26	Regreasable Ball Bearing	
9	209030	18	22	24	26	Flange Bearing Connector	
10	209090	36	44	48	52	U-Bolt w/Two Nuts Plated	3/8"
		72	88	96	104	Lock Washer Plated	3/8"
11	207342	18	22	24	26	Convex Spacer	
12	207339	28	30	34	40	Double End Spacer	
13	206613	8	10	12	12	Butt Plate	
14	207097	0	2	0	0	4-Disc Axle	39"
	207420	0	0	4	0	5-Disc Axle	37"
	209359	4	4	6	8	6-Disc Axle	45"
	209360	2	2	2	2	7-Disc Axle	53"
	209361	2	2	0	2	8-Disc Axle	61"
15	208831	8	10	12	12	Square Nut	1 1/8"

Implements are shipped with extra disc on outside of each rear wing
 The outside discs on front wings are tapered 2" and the outside
 two discs on rear wings are tapered 2" and 4".

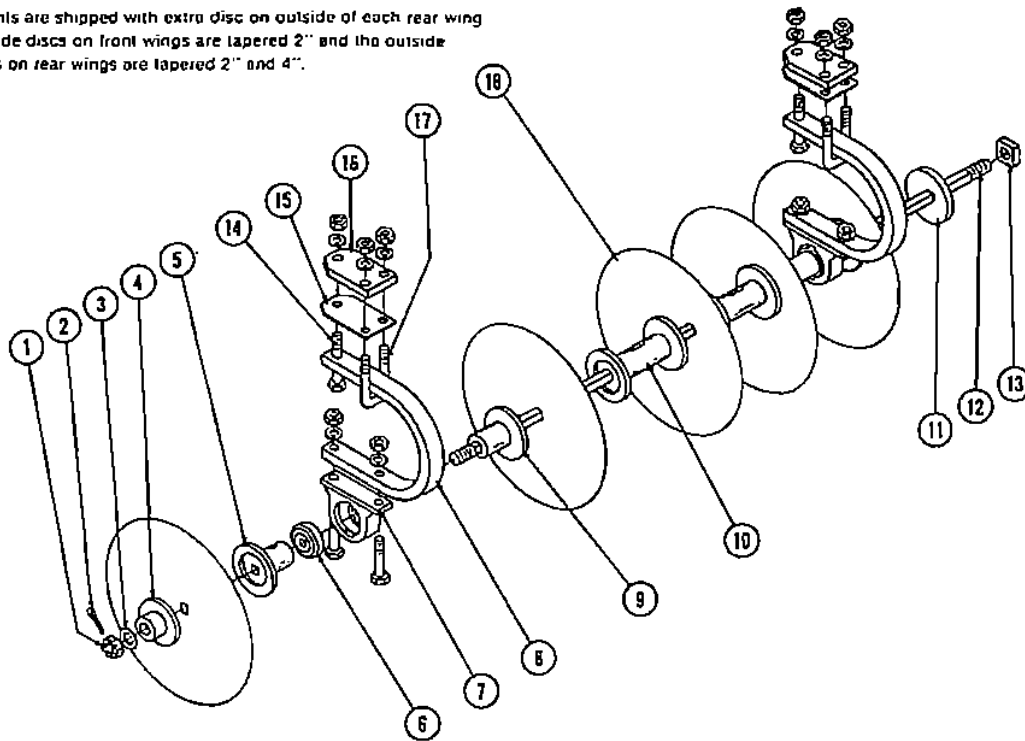

FIG. 3 — SPRING BEARING CONNECTOR DISC GANG ASSEMBLY

Item No.	Part Number	FOR MODELS				Description	Size
		200061	200062	200063	200064		
1		8	10	12	12	Hex Slotted Nut	1 1/8"
2		8	10	12	12	Cotter	3/16" x 2"
3		8	10	12	12	Flat Washer	1 1/4"
4	204704	8	10	12	12	End Washer	
5	207341	18	22	24	26	Concave Spacer	
6	207359	18	22	24	26	Ball Bearing	
7	208155	18	22	24	26	Bearing Housing	
		36	44	48	52	Bolt w/Nut	5/8" x 3"
		36	44	48	52	Lock Washer	5/8"
8	207664	18	22	24	26	Spring Bearing Connector	
9	207342	18	22	24	26	Convex Spacer	
10	207339	26	30	34	40	Double End Spacer	
11	206613	8	10	12	12	Butt Plate	
12	207097	0	2	0	0	4-Disc Axle	29"
	207420	0	0	4	0	5-Disc Axle	37"
	209359	4	4	6	8	6-Disc Axle	45"
	209360	2	2	2	2	7-Disc Axle	53"
	209361	2	2	0	2	8-Disc Axle	61"
13	208831	8	10	12	12	Square Nut	1 1/8"
14		18	22	24	26	Bolt w/Nut	3/4" x 6"
		18	22	24	26	Lock Washer	3/4"
15	208468	18	22	24	26	Support Plate	
16	207823	18	22	24	26	Top Plate	
17	207845	18	22	24	26	U-Bolt w/Two Nuts	3/4"
		36	44	48	52	Lock Washer	3/4"
18	208944	48	56	64	72	20" x 8 Ga. Round Disc	
	208946	4	4	4	4	18" x 8 Ga. Round Disc	
	208439	2	2	2	2	16" x 9 Ga. Round Disc	
	208943	48	56	64	72	20" x 8 Ga. Cut-Out Disc	
	208945	4	4	4	4	18" x 8 Ga. Cut-Out Disc	
	208440	2	2	2	2	16" x 9 Ga. Cut-Out Disc	
	208942	48	56	64	72	22" x 8 Ga. Round Disc	
	208944	4	4	4	4	20" x 8 Ga. Round Disc	
	208946	2	2	2	2	18" x 8 Ga. Round Disc	
	208947	48	56	64	72	22" x 8 Ga. Round Disc	
	208943	4	4	4	4	20" x 8 Ga. Cut-Out Disc	
	208945	2	2	2	2	18" x 8 Ga. Cut-Out Disc	

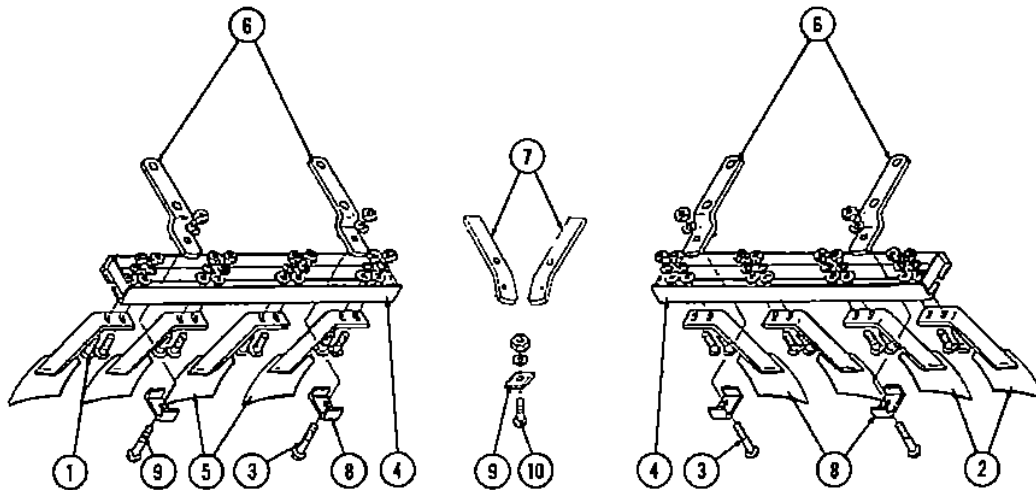
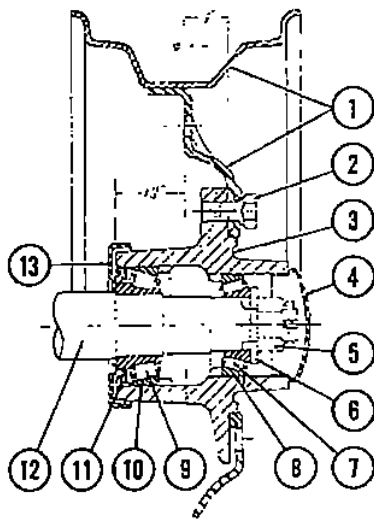

FIG. 4 — SCRAPER BAR ASSEMBLY
(USED ON REAR GANG)

Item No.	Part Number	FOR MODELS								Description	Size
		200 051	200 052	200 053	200 054	200 061	200 062	200 063	200 064		
1		108	124	140	156	108	124	140	156	Carriage Bolt w/Nut	1/2" x 1 1/2"
		108	124	140	156	108	124	140	156	Lock Washer	1/2"
		108	124	140	156	108	124	140	156	Flat Washer	1/2"
		27	31	35	39	27	31	35	39	Scraper	
2	209107	18	22	24	26	18	22	24	26	Bolt w/Nut	1/2" x 2 1/2"
		18	22	24	26	18	22	24	26	Lock Washer	1/2"
3		18	22	24	26	18	22	24	26	Flat Washer	1/2"
		0	2	0	0	0	2	0	0	4-Disc Scraper Bar	
4	209094	0	0	4	0	0	0	4	0	5-Disc Scraper Bar	
	209097	4	4	6	8	4	4	6	8	6-Disc Scraper Bar	
	209099	2	2	2	2	2	2	2	2	7-Disc Scraper Bar	
	209101	2	2	0	2	2	2	0	2	8-Disc Scraper Bar	
	209103	27	31	35	39	27	31	35	39	Scraper	
	209105	18	22	24	26	0	0	0	0	Scraper Bar Bracket	
	209093	0	0	0	0	18	22	24	26	Scraper Bar Brkt.	
	209371	24	28	32	36	24	28	32	36	Scraper Bar Cuff	
5	209223	24	28	32	36	24	28	32	36	Cuff Connector	
		6	6	8	10	6	6	8	10	Carriage Bolt w/Nut	1/2" x 1 1/2"
6		6	6	8	10	6	6	8	10	Lock Washer	1/2"



WHEEL HUB COMPLETE —
SEE ITEM 14.
REPAIR KIT — SEE ITEM 15.

Item No.	Part Number	200051	200053	Description	Size
		200052	200054		
1	208861	6	8	15" x 8" Wheel for Rubber	
2	403817	36	48	Lug Bolt	
3	204515	6	8	Wheel Hub w/Two Cups	
4	204523	6	8	Hub Cup	
5	204522	6	8	Bearing Adjustment Nut	
6	204521	6	8	Cotter	1/2" x 1 1/2"
7	204524	6	8	Flat Washer	3/8"
8	203021	6	8	Bearing Cone	
9	204526	6	8	Bearing Cup	
10	204525	6	8	Bearing Cone	
11	204527	6	8	Bearing Cup	
12	209050	6	8	Grease Seal	
13	204520	6	8	Wheel Axle Assembly	
14	207889	6	8	Dust Collar	
15	207937	6	8	Wheel Hub (Complete)	
				Includes Items 2, 3, 4, 5, 6, 7, 8, 9, 10, 11, & 13.	
				Repair Kit (Includes Items 7, 8, 9, 10 & 11).	

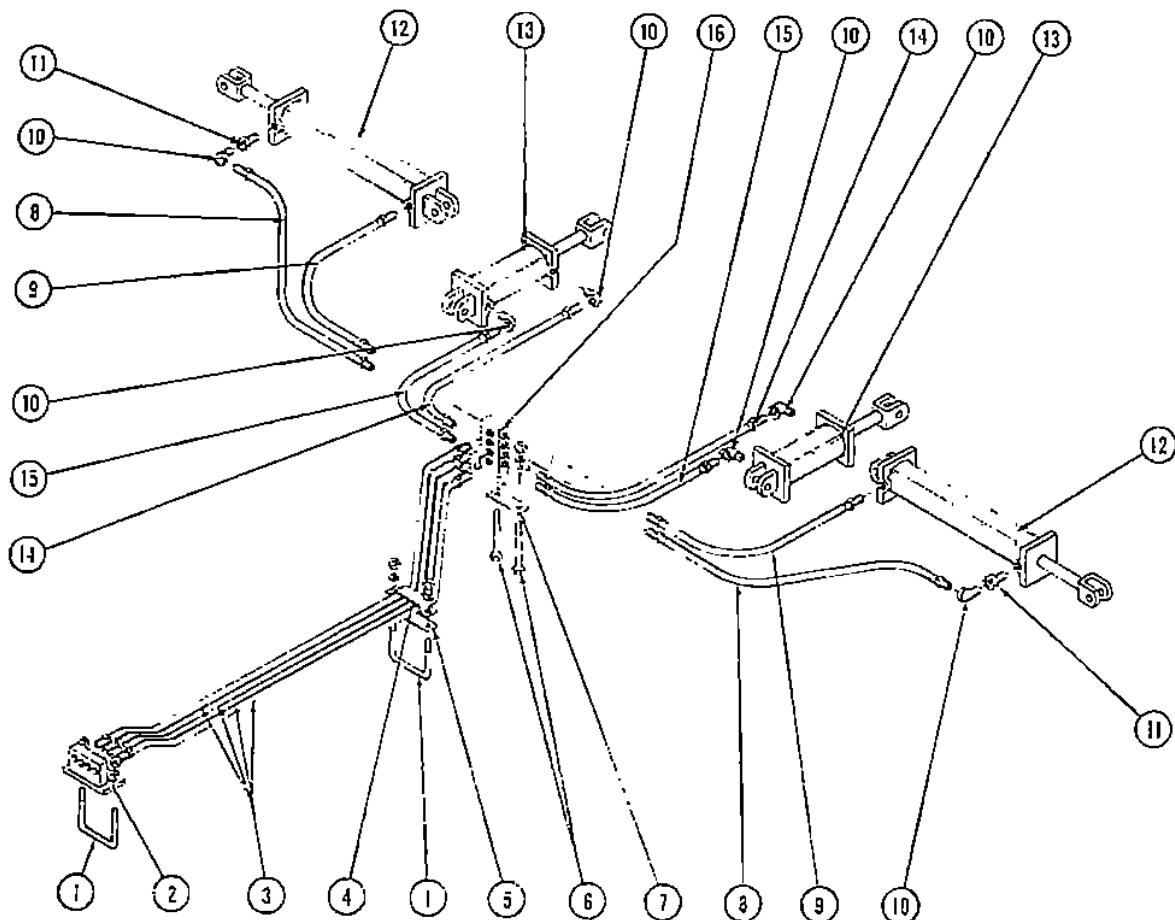

FIG. 6 — HYDRAULIC ASSEMBLY

Item No.	Part Number	FOR MODELS								Description	Size
		200 051	200 052	200 053	200 054	200 051	200 062	200 063	200 064		
1	209090	2	2	2	2	2	2	2	2	U-Bolt	
		4	4	4	4	4	4	4	4	Nut	3/8"
		4	4	4	4	4	4	4	4	Lock Washer	5/8"
2	209179	1	1	1	1	1	1	1	1	Header	
3	209227	4	4	4	4	4	4	4	4	Hydraulic Hose	1/2" x 88"
4	209173	1	1	1	1	1	1	1	1	Hydraulic Hose Holder	
5	209174	1	1	1	1	1	1	1	1	Hose Holder Base	
6		2	2	2	2	2	2	2	2	Bolt w/Nut	5/8" x 6 1/2"
		2	2	2	2	2	2	2	2	Lock Washer	5/8"
7	209178	1	1	1	1	1	1	1	1	Connector Strap	
8	209225	2	2	2	2	2	2	2	2	Hydraulic Hose	1/2" x 38"
9	209224	2	2	2	2	2	2	2	2	Hydraulic Hose	1/2" x 23"
10	207982	6	6	6	6	6	6	6	6	90° Elbow	1/2"
11	208569	2	2	2	2	2	2	2	2	Flow Restrictor	
12	207987	2	2	2	2	2	2	2	2	Hydraulic Cylinder	4" x 24"
13	209134	2	2	2	2	2	2	2	2	Hydraulic Cylinder	4" x 8"
14	209226	2	2	2	2	2	2	2	2	Hydraulic Hose	1/2" x 45"
15	209225	2	2	2	2	2	2	2	2	Hydraulic Hose	1/2" x 38"
16	209175	1	1	1	1	1	1	1	1	Manifold Assy.	

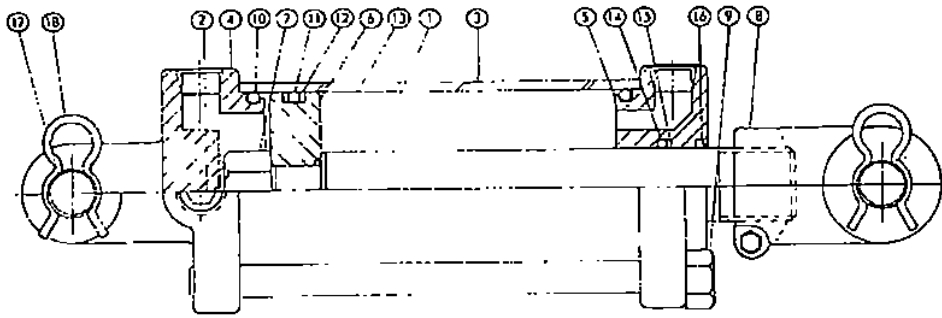

FIG. 7 — PRINCE HYDRAULIC CYLINDER 4" BORE MODEL PMC-9408

Item No.	Part Number	Manufacturer's Number	Number Req'd.	Description	Size
1	209230	011000006	2	Piston Rod	
2	208602	200200021	4	Pipe Plug	
3	209231	051900008	2	Tube	
4	208846	141900006	2	Butt	
5	208847	081900005	2	Gland	
6	208848	071900003	2	Piston	
7	208849	220000212	2	Lock Nut	
8	208850	100000043	2	Clevis Assembly	
9	209232	170301133	8	Tie Rod	
	208860	PMCK-9400	2	Packing Kit (Includes Item 10 thru 15)	
*10	208852	240001342	4	O-Ring	
*11	208853	240000342	2	O-Ring	
*12	208854	240005342	4	B/U Washer	
*13	208855	240000026	2	O-Ring	
*14	208856	240000327	2	O-Ring	
*15	208857	240005327	2	B/U Washer	
16	208858	250001327	2	Wiper	
17	208859	190400004	4	Clevis Pin	
18	208617	190400002	8	Hair Pin Clip	
19	209134	PMC-9408	2	Hydraulic Cylinder (Complete)	4"x8"

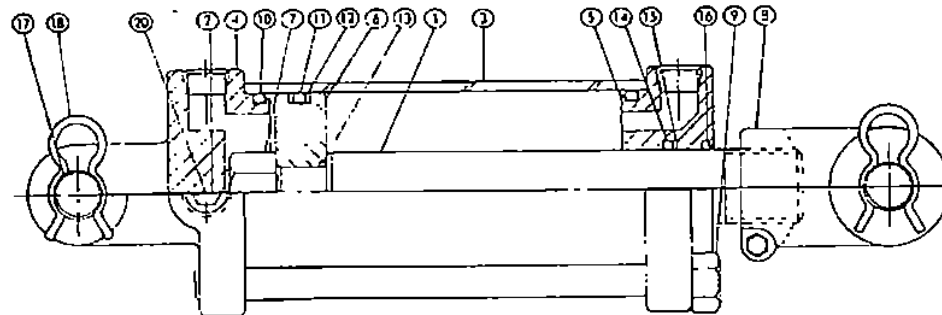

FIG. 8 — PRINCE HYDRAULIC CYLINDER 4" BORE MODEL PMC-9424

Item No.	Part Number	Manufacturer's Number	Number Req'd.	Description	Size
1	208844	011000012	2	Piston Rod	
2	208602	200200021	4	Pipe Plug	
3	208845	051900015	2	Tube	
4	208846	141900006	2	Butt	
5	208847	081900005	2	Gland	
6	208848	071900003	2	Piston	
7	208849	220000212	2	Lock Nut	
8	208850	100000043	2	Clevis Assembly	
9	208851	170301293	8	Tie Rod	
	208860	PMCK-9400	2	Seal Kit (Includes Item 10 thru 15)*	
10	208852	240001342	4	O-Ring	
11	208853	240000342	2	O-Ring	
12	208854	240005342	4	B/U Washer	
13	208855	240000026	2	O-Ring	
14	208856	240000327	2	O-Ring	
15	208857	240005327	2	B/U Washer	
16	208858	250001327	2	Wiper	
17	208859	190400004	4	Clevis Pin	
18	208617	190400002	8	Hairpin Clip	
19	207987	PMC-9424	2	Hydraulic Cylinder (Complete)	4"x24"
20	208569		2	Flow Restrictor (Not Shown)	

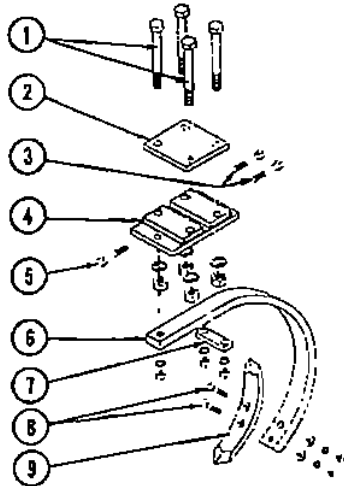

FIG. 9 — BALK BREAKER ATTACHMENT
MACH. NO. 299082

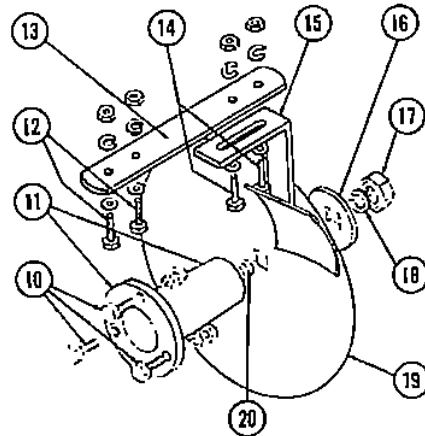

FIG. 10 — FURROW FILLER ATTACHMENT
MACH. NO. 200080

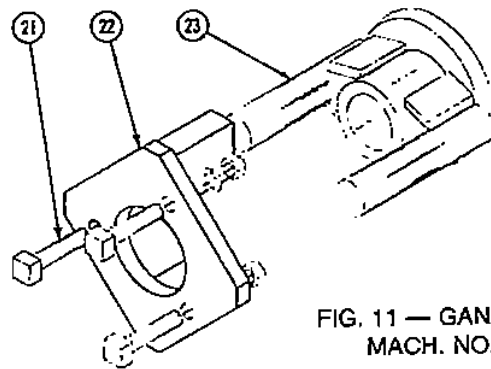

FIG. 11 — GANG COUPLER
MACH. NO. 200092

Item No.	Part Number	FOR MODEL 200-				Description	Size
		051, 061	052, 062	053, 063	054, 064		
1	209369	4	4	4	4	Bolt w/Nut	3/4" x 7 1/2"
		4	4	4	4	Lock Washer	3/4"
2	209259	1	1	1	1	Plate	
3		2	2	2	2	Bolt w/Nut	3/8" x 3"
		2	2	2	2	Lock Washer	5/16"
4	209258	1	1	1	1	Shank Connector	3/8" x 2 1/2"
5		1	1	1	1	Bolt w/Nut	3/8"
		1	1	1	1	Lock Washer	
6	206726	1	1	1	1	22" Shank	
7	603710	1	1	1	1	Support Strap	
8		2	2	2	2	Plow Bolt	7/16" x 2 1/4"
		2	2	2	2	Lock Washer	7/16"
		2	2	2	2	Flat Washer	7/16"
9	603014	1	1	1	1	Chisel	
10		6	6	6	6	Bolt w/Nut	1/2" x 1 1/2"
		6	6	6	6	Lock Washer	1/2"
11	206629	2	2	2	2	Furrow Filler Spacer	
12		4	4	4	4	Bolt w/Nut	1/2" x 2"
		4	4	4	4	Flat Washer	1/2"
		4	4	4	4	Lock Washer	
13	206797	2	2	2	2	Furrow Filler Scraper Bar	
14		4	4	4	4	Bolt w/Nut	1/2" x 1 1/2"
		4	4	4	4	Flat Washer	1/2"
		4	4	4	4	Lock Washer	1/2"
15	204909	1	1	1	1	Right Scraper (for Left Rear)	
	204911	1	1	1	1	Left Scraper (for Right Rear)	
16	203986	2	2	2	2	Furrow Filler Out Plate	
17		2	2	2	2	Hex Nut	7/8"
18		2	2	2	2	Lock Washer	7/8"
19	204000	2	2	2	2	16" Round Disc	
	204001	2	2	2	2	18" Round Disc	
20		2	2	2	2	Bolt	3/8" x 2 1/4"
21		12	18	24	24	Bolt w. Nut	1/2" x 2 1/4"
		12	18	24	24	Lock Washer	
22	207315	4	8	8	8	Butt Plate Driver	
23	207307	4	8	8	8	End Washer Drive	

BUNDLING LIST

Hydraulic Folding — Flexible Wheel Tandem Harrow

General

Right and left are determined by standing at the rear of the harrow. All items designated as right and left fit into their respective positions on the front section. When used on the rear section, the procedure is reversed and items designated as right will fit onto the left side and vice versa. These harrows are shipped "Knocked Down" and are bundled into the bundles listed on opposite page.

Bundle Number Tag Index

Bundles for Disc Gang Assemblies may vary with the type of bearing connector; use of gang connectors; size of disc blade and type of bearing. Two bundle number tags are attached to disc gang assemblies to fully describe the bundle.

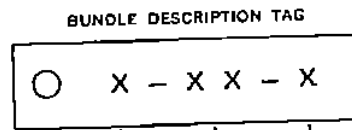
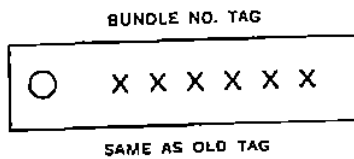

Type of Bearing Connector; or Use of Gang Connectors

Code No.	Description
1	Standard Bearing Connectors
2	Spring Bearing Connectors
3	Standard Bearing Connectors with Gang Connectors
4	Spring Bearing Connectors with Gang Connectors

Disc Blade

Code No.	Part No.	Diameter	Axle or Housing Size	Cut-Out or Round
66	208943	20"	1 1/8" Sq.	C.O.
67	208944	20"	1 1/4" Sq.	Rd.
64	208941	22"	1 1/8" Sq.	C.O.
65	208942	22"	1 1/8" Sq.	Rd.

Type of Bearing

Code No.	Description
1	Gray Iron
2	7/8" Sealed Bearing
3	1 1/8" Sealed Bearing Flange Mount
4	1 1/8" Sealed Bearing Pillow Block Mount
5	1 1/8" Regreasable Bearing Flange Mount
6	1 1/8" Regreasable Bearing Pillow Block Mount
7	1 1/2" Regreasable Bearing
8	1 1/2" Special Regreasable Bearing

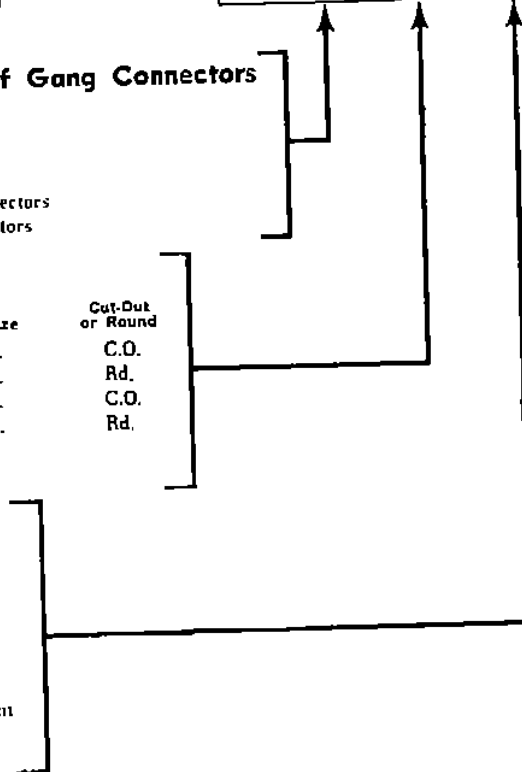

Bundle Numbers	200 051	200 052	200 053	200 054	200 061	200 062	200 063	200 064	Description
201481	1	1	1	1	1	1	1	1	Small Tongue
201482	1	1	1	1	1	1	1	1	Main Frame
201483	1	1	1	1	1	1	1	1	Small Wheel Axle
201484	1	1	0	0	1	1	0	0	14 3/4" Right Wing
201485	1	1	0	0	1	1	0	0	14 3/4" Left Wing
201486	0	0	1	1	0	0	1	1	42" Right Wing
201487	0	0	1	1	0	0	1	1	42" Left Wing
201496	0	2	0	2	0	2	0	2	Short Extension
201498	1	1	1	1	1	1	1	1	Hydraulic Hose
209134	2	2	2	2	2	2	2	2	4" x 8" Hydraulic Cylinder
207987	2	2	2	2	2	2	2	2	4" x 24" Hydraulic Cylinder
201556	1	1	1	1	1	1	1	1	Tongue Connector
201450	6	6	8	8	6	6	8	8	Rims 15" x 8"
201555	1	1	1	1	1	1	1	1	Jack
201502	0	1	0	0	0	0	0	0	Right Rear 4-Disc Gang
201503	0	1	0	0	0	0	0	0	Left Rear 4-Disc Gang
201504	0	0	1	0	0	0	0	0	Right Front 5-Disc Gang
201505	0	0	1	0	0	0	0	0	Left Front 5-Disc Gang
201506	0	0	1	0	0	0	0	0	Right Front 5-Disc Gang
201507	0	0	1	0	0	0	0	0	Left Front 5-Disc Gang
201508	1	0	0	1	0	0	0	0	Right Front 6-Disc Gang
201509	1	0	0	1	0	0	0	0	Left Front 6-Disc Gang
201510	1	2	2	3	0	0	0	0	Right Front or Left Rear 6-Disc Gang
201511	1	2	2	3	0	0	0	0	Left Front or Right Rear 6-Disc Gang
201512	0	0	1	0	0	0	0	0	Right Rear 6-Disc Gang
201513	0	0	1	0	0	0	0	0	Left Rear 6-Disc Gang
201514	1	1	1	1	0	0	0	0	Right Front 7-Disc Gang
201515	1	1	1	1	0	0	0	0	Left Front 7-Disc Gang
201516	0	1	0	0	0	0	0	0	Right Front 8-Disc Gang (Inside)**
201517	0	1	0	0	0	0	0	0	Left Front 8-Disc Gang (Inside)**
201518	1	0	0	1	0	0	0	0	Right Rear 8-Disc Gang (Outside)**
201519	1	0	0	1	0	0	0	0	Left Rear 8-Disc Gang (Outside)**
201520	0	0	0	0	0	1	0	0	Right Rear 4-Disc Gang*
201521	0	0	0	0	0	1	0	0	Left Rear 4-Disc Gang*
201522	0	0	0	0	0	0	1	0	Right Front 5-Disc Gang*
201523	0	0	0	0	0	0	1	0	Left Front 5-Disc Gang*
201524	0	0	0	0	0	0	1	0	Right Front 5-Disc Gang*
201525	0	0	0	0	0	0	1	0	Left Front 5-Disc Gang*
201526	0	0	0	0	1	0	0	1	Right Front 6-Disc Gang*
201527	0	0	0	0	1	0	0	1	Left Front 6-Disc Gang*
201528	0	0	0	0	1	2	2	3	Right Front or Left Rear 6-Disc Gang*
201529	0	0	0	0	1	2	2	3	Left Front or Right Rear 6-Disc Gang*
201530	0	0	0	0	0	0	1	0	Right Rear 6-Disc Gang*
201531	0	0	0	0	0	0	1	0	Left Rear 6-Disc Gang*
201532	0	0	0	0	1	1	1	1	Right Front 7-Disc Gang*
201533	0	0	0	0	1	1	1	1	Left Front 7-Disc Gang*
201534	0	0	0	0	0	1	0	0	Right Front 8-Disc Gang* (Inside)**
201535	0	0	0	0	0	1	0	0	Left Front 8-Disc Gang* (Inside)**
201536	0	0	0	0	1	0	0	1	Right Rear 8-Disc Gang* (Outside)**
201537	0	0	0	0	1	0	0	1	Left Rear 8-Disc Gang* (Outside)**
201538	0	0	0	1	0	0	0	0	Right Rear 8-Disc Gang (Center)**
201539	0	0	0	1	0	0	0	0	Left Rear 8-Disc Gang (Center)**
201540	0	0	0	0	0	0	0	1	Right Rear 8-Disc Gang* (Center)**
201541	0	0	0	0	0	0	0	1	Left Rear 8-Disc Gang* (Center)**
201548	1	1	0	0	1	1	0	0	Right Wing Wheel Lift
201549	1	1	0	0	1	1	0	0	Left Wing Wheel Lift
201550	0	0	1	1	0	0	1	1	Right Wing Wheel Lift
201551	0	0	1	1	0	0	1	1	Left Wing Wheel Lift
TOTAL	38	32	34	38	28	32	34	38	

Note:

- Spring Bearing Hanger.
- Location of Middle Bearing Hanger:
- (Center) — between the center two discs.
- (Inside) — between fifth and sixth disc from butt plate.
- (Outside) — between third and fourth disc from butt plate

SETTING-UP INSTRUCTIONS

Hydraulic Folding — Flexible Wheel Tandem Harrow

General

Right and left are determined by standing at the rear of the harrow. All items designated as right and left fit into their respective positions on the front section. When used on the rear section, the procedure is reversed and items designated as right will fit onto the left side and vice versa.

These harrows are shipped "Knocked Down" and are bundled as shown on chart, page no. 11.

Basic Harrow Assembly

When setting up unit refer to parts list, and diagrams on preceding pages to identify descriptions of parts and assemblies; also refer to bundle list to identify the bundles that are used on your particular harrow. Remove all bundling wire and proceed as follows: Remember right and left are determined by viewing from the rear of harrow.

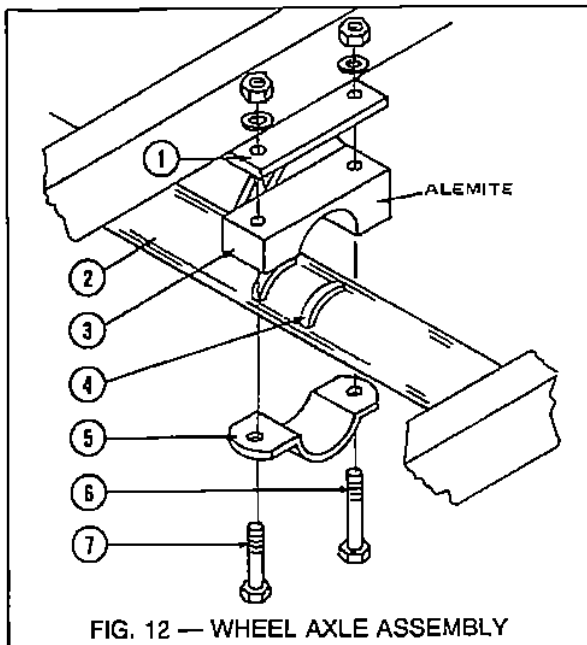

1. Main Frame Placement:

Place wheel axle bundle (201483) in center of working area with axles for tires toward the rear of unit, and hydraulic cylinder brackets upward (refer to Fig. 1). Place main frame bundle (201482) approximately four feet above wheel axle supported by 2 or 4 standards. Place standards in such a way as to not interfere with wheel axle connections. Be sure main frame is right side up with wing stop brackets and hydraulic hose manifold up.

2. Wheel Axle Assembly: (See Fig. 12)

Position center frame wheel axle below main frame with axles for tires to the rear and hydraulic cylinder bracket upward. Align axle toward front of unit with wheel lift bearings (Item 3) directly below brackets on main frame (Item 1). Remove $\frac{3}{4}$ " bolts connecting bearings (Item 7) to wheel lift. Be sure Alemite on wheel axle bearing is toward the rear. With bearing (Item 3) on top of wheel lift (Item 2) raise for proper positioning below brackets (Item 1). Place wheel lift strap (Item 5) flush with lift roll, and long side of strap turned to the front. Replace long bolt (Item 6) from bottom side through rear hole, connecting strap, bearing, and main frame bracket. Replace short bolt (Item 7) through front hole. Do not tighten bolts until wheel lift is completely connected. Use this same procedure for connecting other 2 points. Be sure bearings are aligned between key steel (Item 4) on wheel lift for proper positioning. Mount four 8" x 15" rims with four 9.5L x 15" tires with six $\frac{1}{2}$ " lug bolts on hubs of main wheel axle.

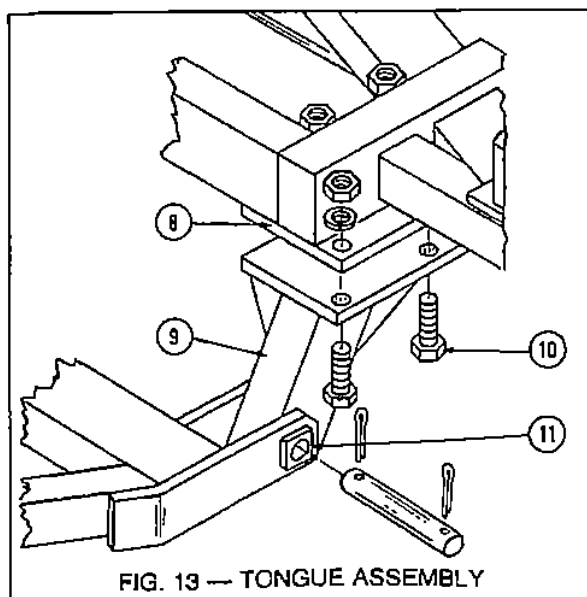

3. Tongue Assembly: (See Fig. 13)

Remove bundling wire from the two tongue connectors (bundle 201556). Also remove the eight $\frac{3}{4}$ " bolts (Item 10) from the tongue connectors (Item 9). Place the left tongue connector flush with brackets (Item 8) on the underside at the front of the main frame. Connectors should be protruding toward the front of harrow. Then replace the four $\frac{3}{4}$ " bolts from bottom side. Repeat procedure for right side. Then position tongue, aligning holes of tongue (Item 11) with holes of connectors, and pin. Be sure leveling arm on tongue is on right side of tongue viewing from the rear of unit. Place manual jack on front of tongue.

4. Depth Control Assembly: (See Fig. 14)

Remove pin (Item 12) and depth control cuff (Item 15) from the two depth gauge bars (Item 13) and slide the end with holes through the brackets on rear main frame (Item 14) and pin the other end to bracket on main wheel lift (Item 16). Replace depth control cuff behind bracket of main frame.

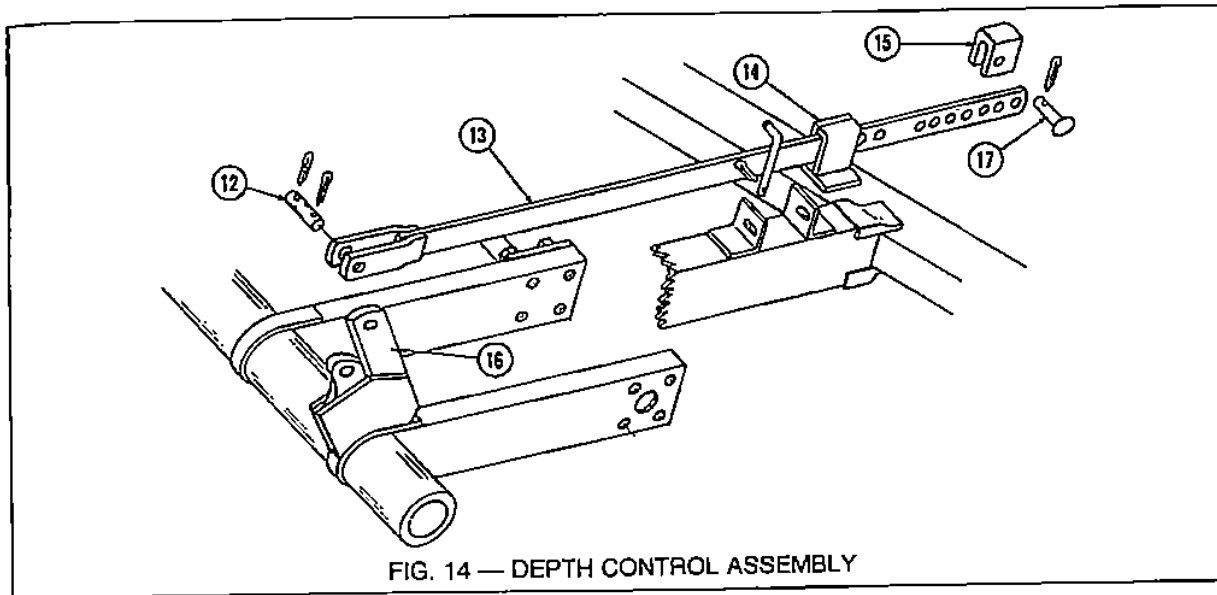

FIG. 14 — DEPTH CONTROL ASSEMBLY

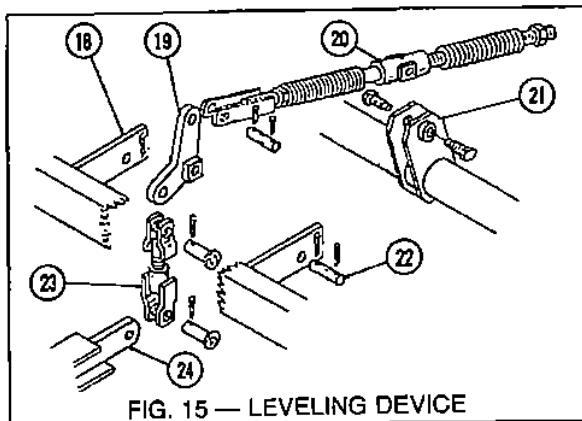

FIG. 15 — LEVELING DEVICE

5. Leveling Device Connection: (See Fig. 15)

The leveling device and spring rod are bundled with the tongue bundle 201481. Remove pin (Item 22) from brackets on right side of front main frame (Item 18). Position leveling arm (19) between brackets with spring rod to the top and rear of the harrow. Make sure long end of leveling arm is extending upward. Remove the two $\frac{3}{8}$ " bolt screws from bracket (Item 21) on wheel lift and position spring rod slide (Item 20) between brackets with holes aligned. Replace the two screws, connecting slide to brackets. Then adjust leveling adjustment housing (Item 23) to align with tongue leveling device connector (Item 24). More adjustment can be made by raising or lowering the tongue whichever is necessary to align holes. Now if a tractor with hydraulics is available the implement can be raised off standards and the height of the harrow can be determined by hydraulically controlling the unit. First connect two 4" x 8" hydraulic cylinders to the brackets on the main frame and on the main wheel axle with the ports facing to the center for correct hose connection.

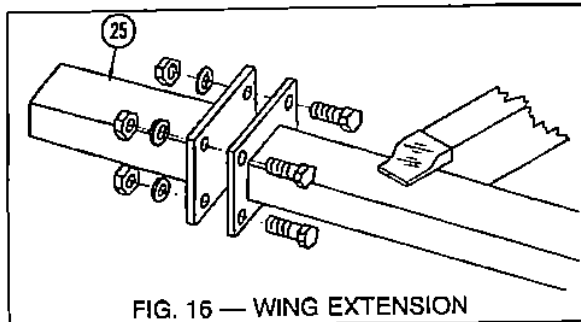

FIG. 16 — WING EXTENSION

6. Wing Extension: (See Fig. 16)

There are two different wing extensions—a long extension (201497) and a short extension (201496). Make sure your unit has either 4 short extensions (Model 200052, 62, 200054-64) or no extensions at all. One bundle has two extensions. If your unit does not have extensions proceed to step 7. Remove the four $\frac{3}{8}$ " bolts from extensions (Item 25) and align holes in extensions with holes in plates on wing gang frame. Replace bolts connecting extension to wing. Repeat procedure for other three extensions.

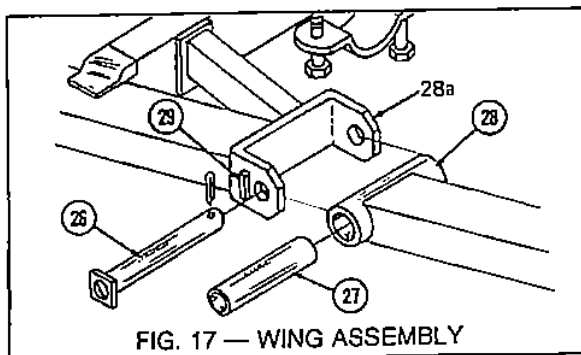

FIG. 17 — WING ASSEMBLY

7. Wing Connections: (See Fig. 17)

Position left wing so that long gang frame is to the rear of unit and wing stop is upward. Remove the two pins (Item 26) and the two bushings (Item 27) from the wing hinges (Item 28a). Insert bushings in main frame hinges (Item 28). It is very important that all four bushings are in place. Connect wing to main frame and slide pins in from outside to lock against keys (Item 29). Repeat procedure for right wing.

8. Wing Wheel Axle Assembly:

Slide wing wheel axles under wing frames with wheel axle for tires to the rear and wheel hubs facing outward (only for models with one hub axles, others have two hubs). Use same connection procedure as in step 2, using Fig. 12 for reference. Mount two or four 9.5L x 15" tires on hubs in same manner as on main wheel axle.

9. Wheel Lift Connectors: (See Fig. 18)

Wheel lift connectors will be located on main frame wheel axle. Remove pin from other end of connector. Then before connecting make sure harrow is level across the entire frame, wings included. Adjust wheel connector (Item 30) until holes in wing bracket align with hole in connector. Once frame is level insert pin (Item 31).

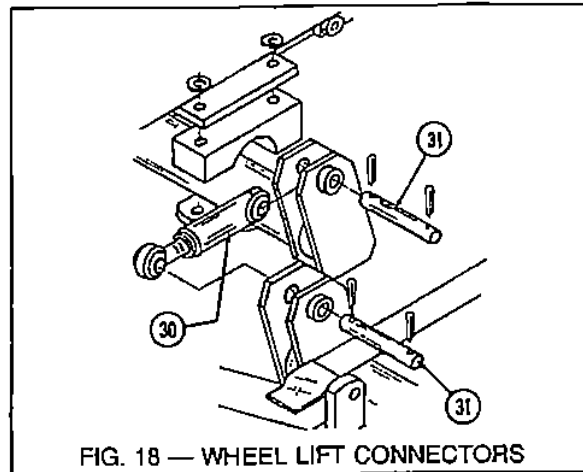

10. Gang Assembly: (Refer to Figs. 19, 20, 21, 22)

Choose one of the following figures which represents your particular model harrow, and study the figure carefully to determine the gang arrangement for your model. The top number in the figure is the gang bundle number for gangs with standard bearing hangers which will be located on the disc gang. The bottom number is the gang bundle number for spring bearing hanger(s). If a tractor with hydraulic system is available control the height of unit by using wheel lift cylinders for easy attachment of bearing hangers. Instructions on how to attach the two types of bearing hangers start on page 16. Read the one for your particular type and then return to finish this section.

Attach all front gangs starting from the center and work outward. Bring the center two gangs as close as possible to each

other to eliminate as much balk as possible. When attaching consecutive gangs space them 8" apart from each other because this is the desired disc spacing. Position rear gangs starting from center in such a way as to have approximately 1" clearance between the two center scraper bars. Remember each gang should be equal distance from the center. Then position each consecutive gang 8" apart from the gang before. Tighten all bolts on gangs as you go; if not when you come back to tighten, the gangs will shift position. Adjust scraper bars to leave 1/2" to 1" spacing from the next one. Then adjust scrapers so they are parallel and approximately 1/8" from disc. Tighten all 1/2" scraper bolts. Remember tighten all bolts, spread all cotters, and grease all fittings.

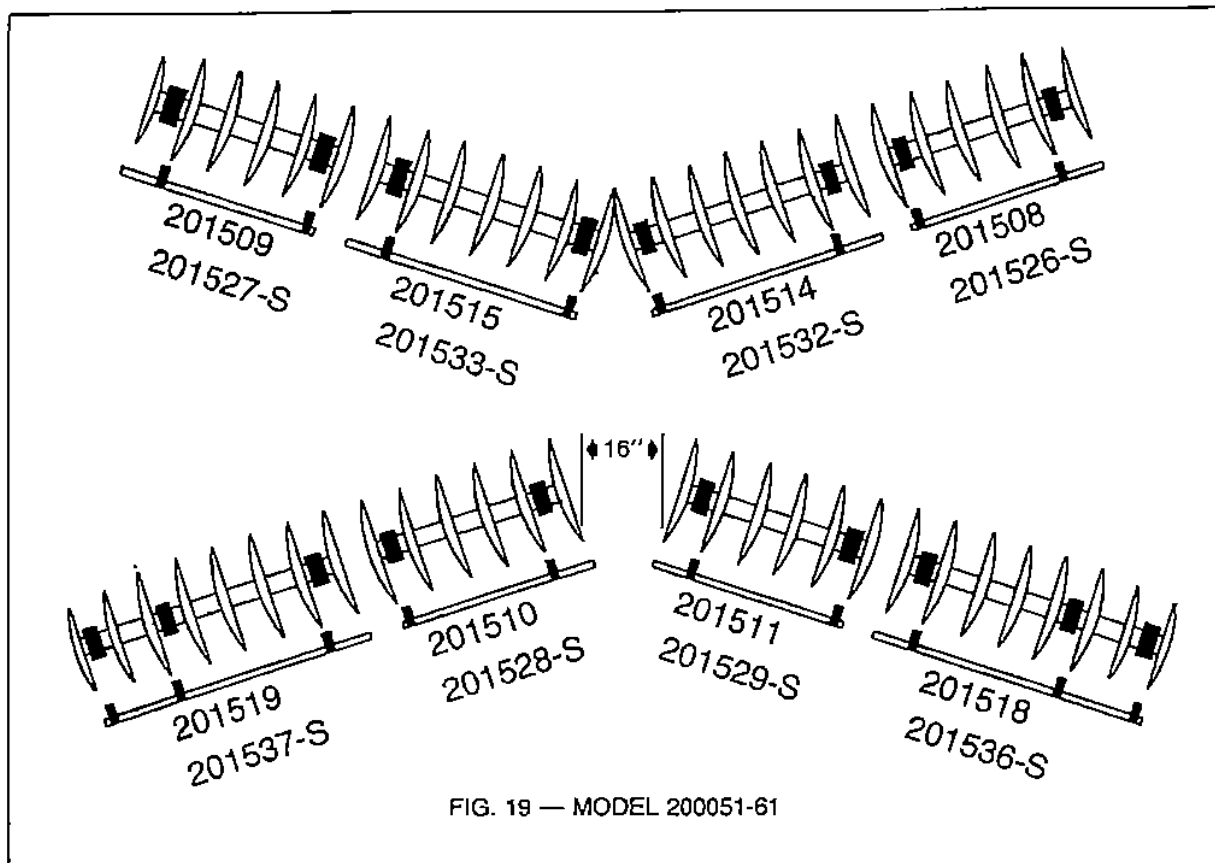

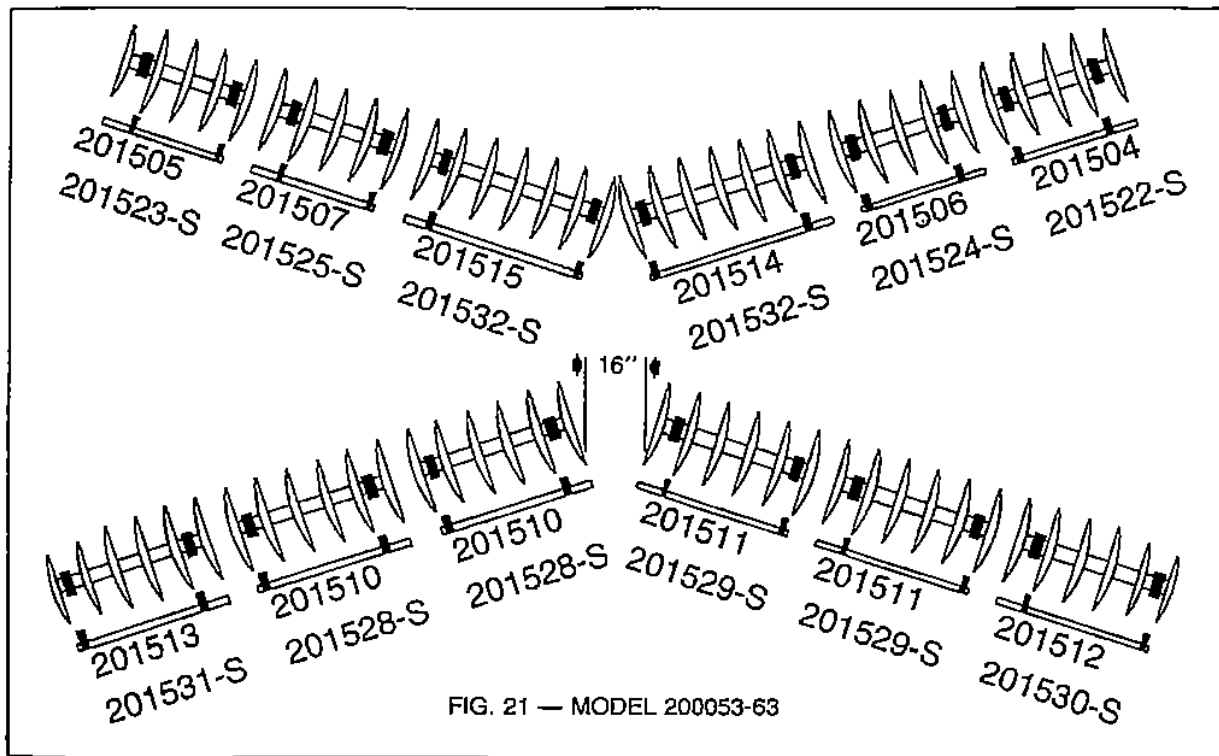
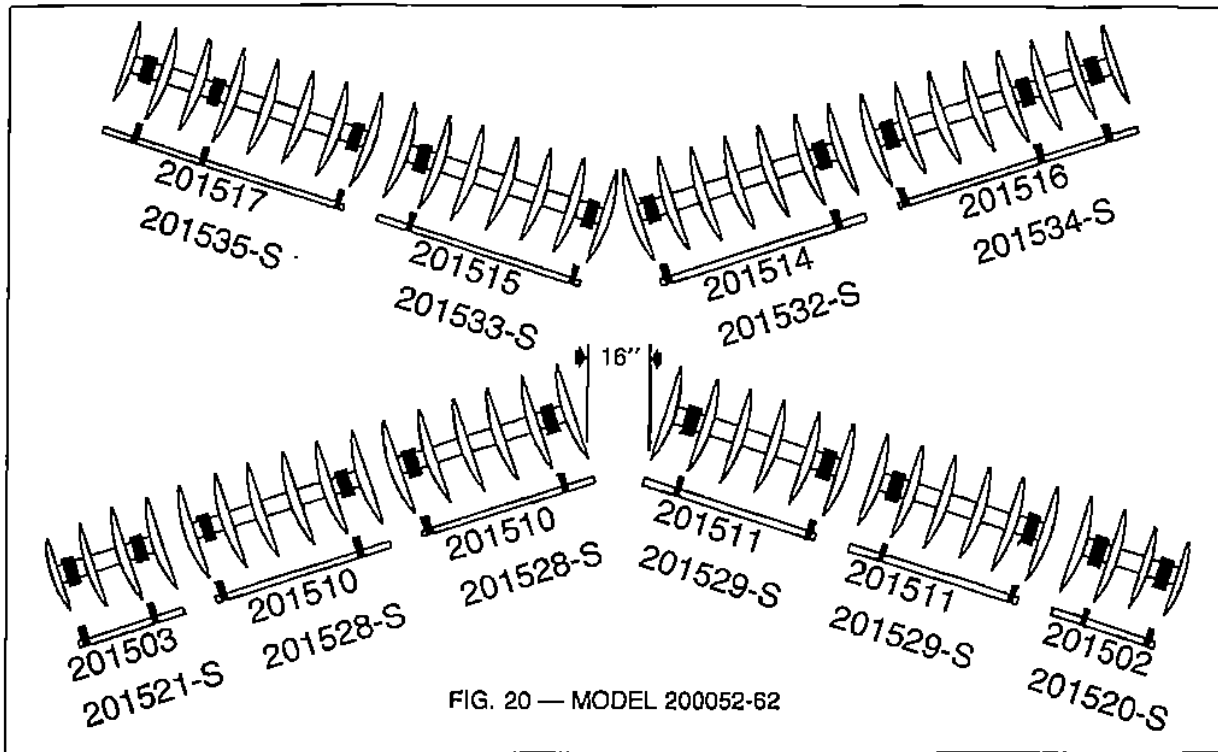

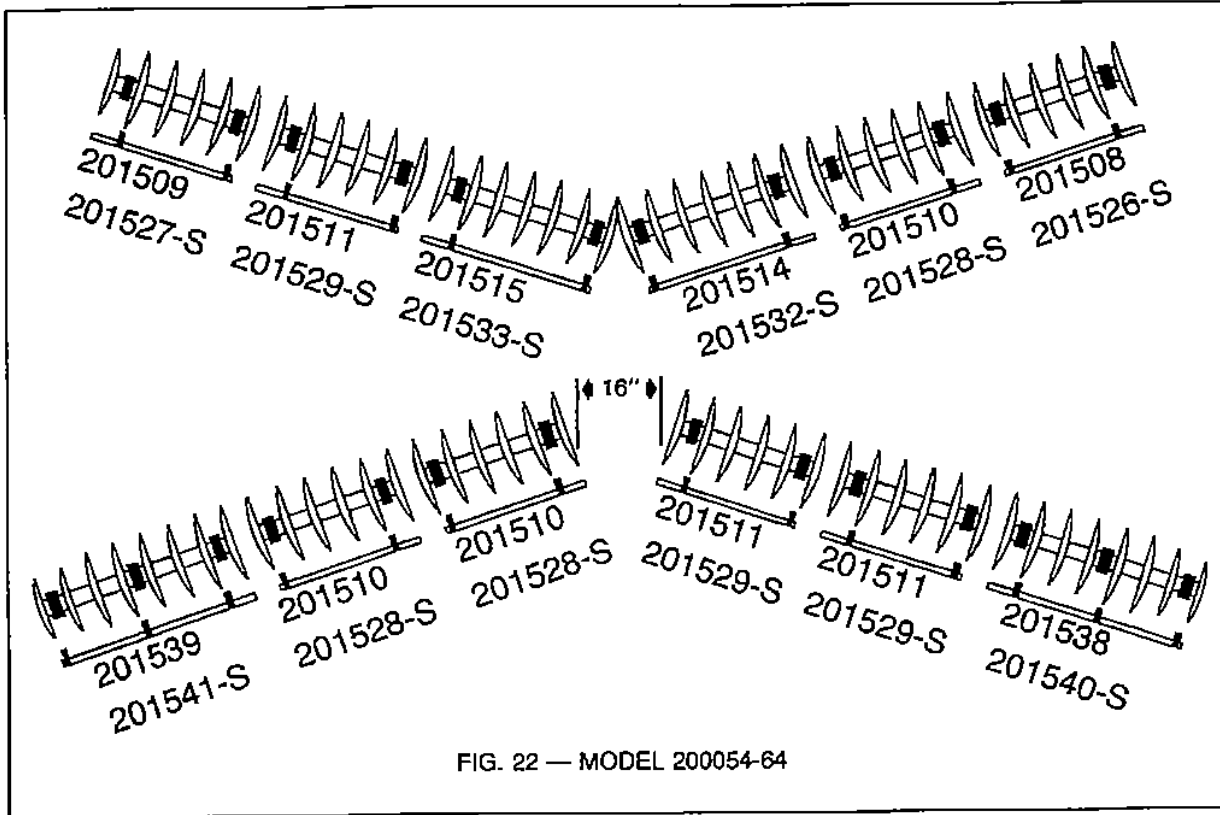

FIG. 22 — MODEL 200054-64

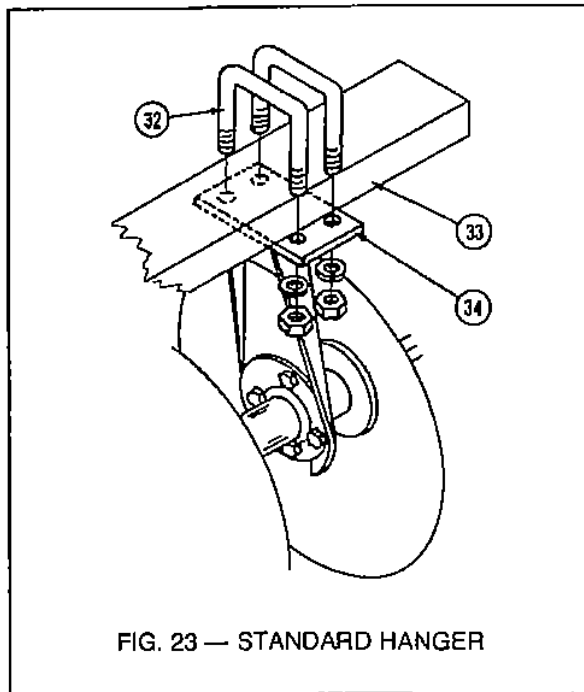

FIG. 23 — STANDARD HANGER

11. Standard Bearing Hangers: (See Fig. 23)

Position right front gang bundle beneath right front gang frame on main frame as far to center as possible. Make sure scrapers are toward the rear. Lower or raise unit to desired height for easy gang attachment. Remove $\frac{3}{4}$ " U-bolts (Item 32) from bearing hanger (Item 34), and place hanger flush with bottom of gang frame (Item 33). Strap U-bolts around frame and through holes in bearing hanger. Do not tighten nuts until all gangs have been connected and positioned.

12. Spring Bearing Hangers: (See Fig. 24)

Position right front gang bundle beneath right front gang frame on main frame as far to center as possible. Make sure scrapers are to rear and hanger is toward front. Lower or raise unit to desired height for easy gang attachment. Remove $\frac{3}{4}$ " single bolt (Item 35) and position hanger in such a way that the gang frame (Item 36) is placed between the small plate (Item 37) and the large plate (Item 38). Nuts on U-bolt may have to be loosened for gang to fit. Then replace bolt. Do not tighten bolts until all gangs have been positioned on frame.

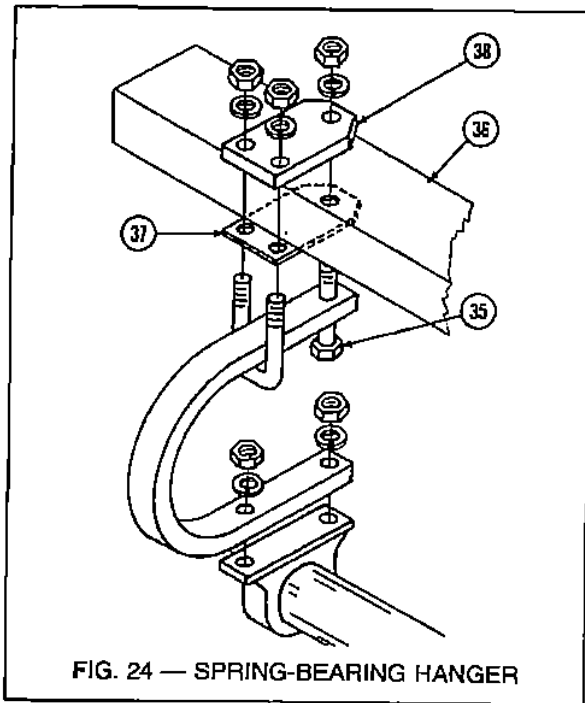

FIG. 24 — SPRING-BEARING HANGER

13. Hydraulic Hose Connection: (See Fig. 25)

Connect the base of two 4" x 8" hydraulic cylinders to the brackets on main frame and rod end to the brackets on wheel lift.

Connect base of the two 4" x 24" hydraulic cylinders to cylinder bracket on main frame and rod end to brackets on wing lift with hose ports facing to the front of unit. Insert 6, 90-degree elbows into hose ports of wheel lift cylinder and rod end of wing cylinder (See Fig. 25). Insert two flow restrictors into rod end of wing cylinders. Each hose has only one swivel so it is important to screw the end without swivel in first. Always tighten each hose end immediately after connection. This is very important on manifold and header. Screw the two 1/2" x 38" hoses into the base end of wheel lift cylinders. Remember to tighten. Screw the other end into the bottom holes on the side of the manifold. Then screw two 1/2" x 45" hoses into the rod end of wheel lift cylinder and into the second from bottom port on the manifold. Remember to tighten. Screw two 1/2" x 38" hoses into the rod ends of the wing cylinders, the other end into third from bottom ports on manifold. Then screw two 1/2" x 23" hoses into the base end of wing cylinders and top ports on manifold. Finally, connect the four 1/2" x 88" hoses into the front of manifold and back of header. Place hose in top port of manifold to right port on header. Connect hose to second from top port on manifold to second from right port on header and so forth. Clamp hoses onto rear of tongue with hose holder to keep hoses from twisting.

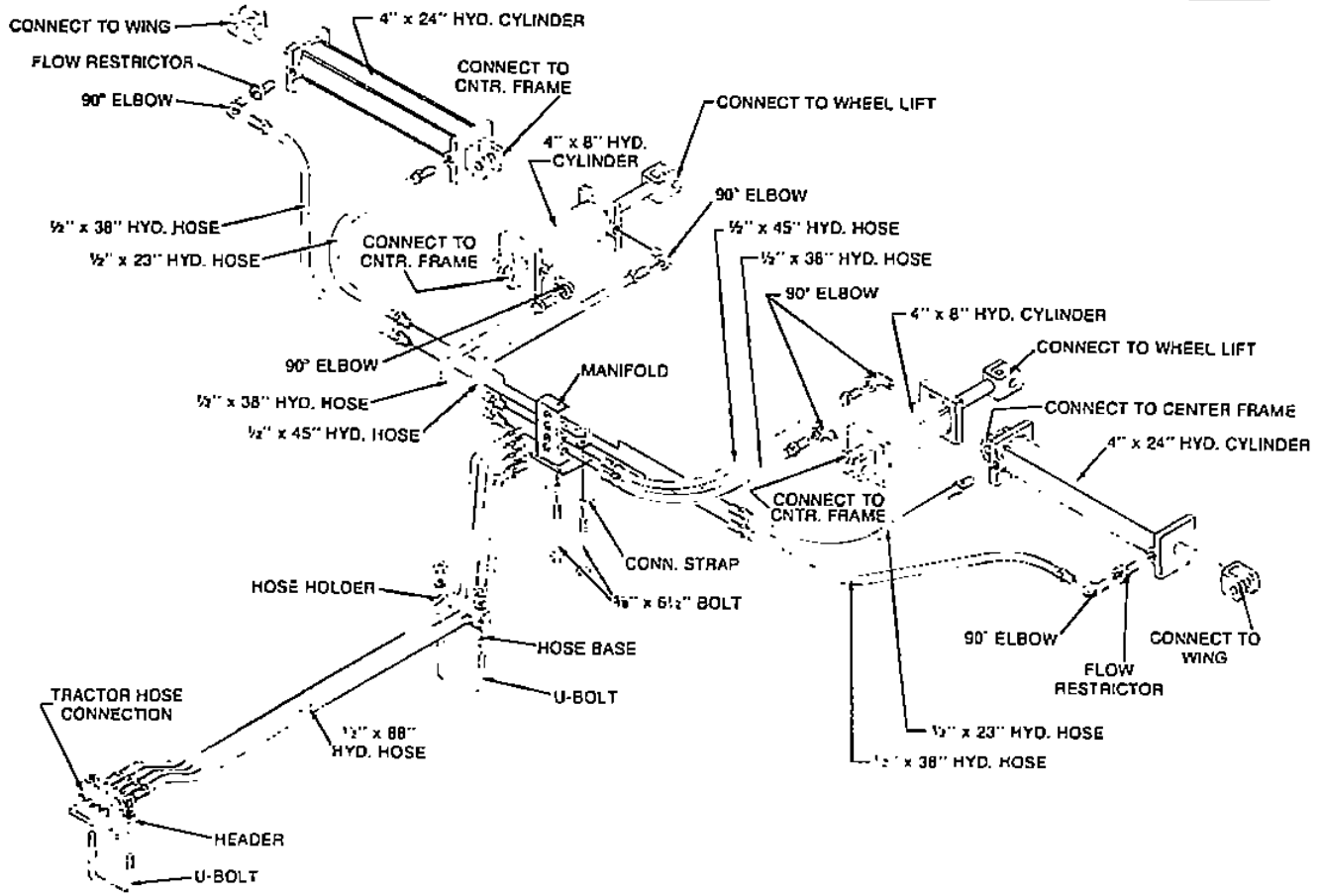
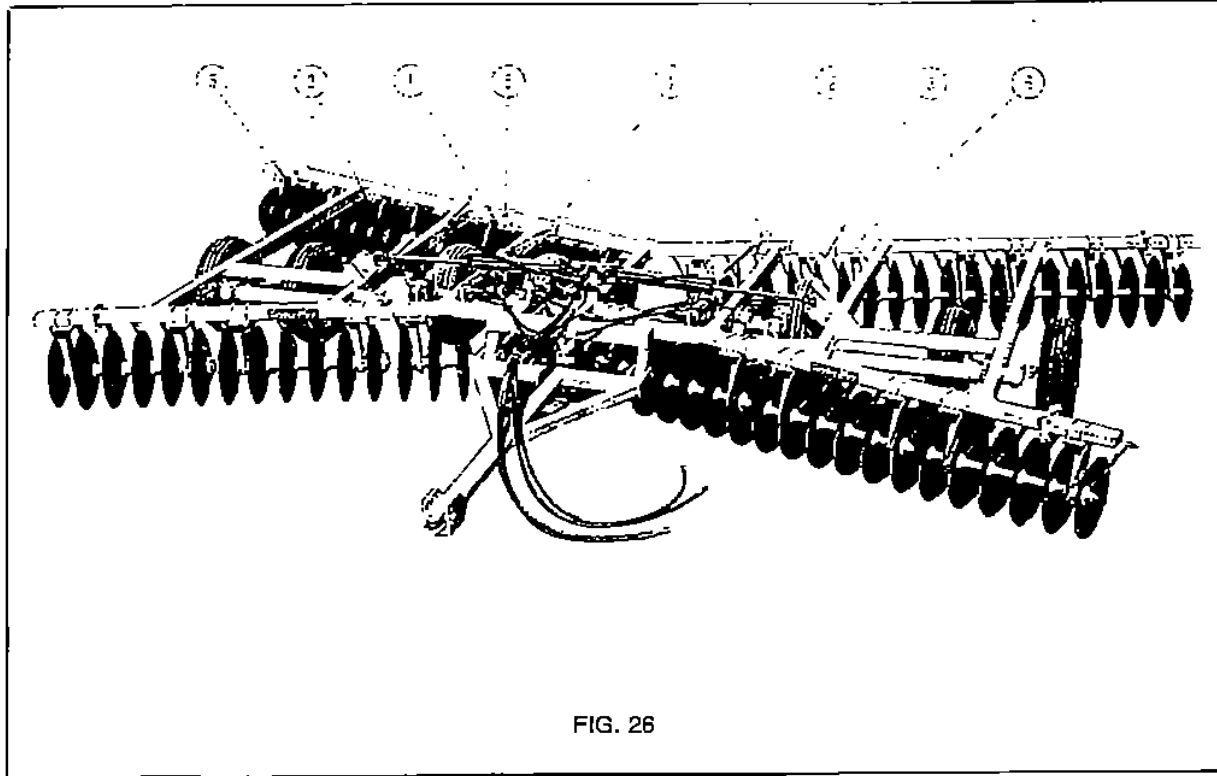

FIG. 25 — HYDRAULIC HOSE ASSEMBLY

OPERATING INSTRUCTIONS



Front to Rear Leveling

See Item 1, Fig. 26

To level the harrow from front to rear, use the spring adjustment rod. Viewing from the rear, screw the two nuts clockwise to make the harrow plow deeper in the rear. Screw the nuts counterclockwise to make the harrow plow deeper in the front. Be sure to keep nuts tight against springs.

Adjustment for Leveling Wing

See Item 2, Fig. 26

The frame and wings should be level across the top. If not, lower the harrow to the plowing position. Remove the pin in the wheel axle connector. Lengthen the wheel axle connector to lower the wing. Shorten the wheel axle connector to raise the wing. Replace the pin in the wheel axle connector.

Adjustment of Wing Float

See Item 3, Fig. 26

The wings can be adjusted to have more floating action in either direction by adjusting the hydraulic cylinder cuff. Screw the cuff "in" for more floating action in the up direction, and "out" for more float in the down direction. Remember, however, in doing this you eliminate floating action in the opposite direction.

Adjusting for Balk

Loosen the U-Bolts holding the bearing connectors (Item 10, Fig. 2) on the front gang frames. Move all front disc gang assemblies (Fig. 2) in toward the center until the butt plates (Item 13, Fig. 2) are touching. Do not let the axles touch. Make sure all U-Bolts are moved the same

distance toward the center before tightening. Loosen the U-Bolt holding the bearing connector on the wings and slide the disc gang in toward the center until the 8" spacing is between the discs on the center section and the wing section.

Adjusting for Ridging and Furrowing

If front to rear leveling does not eliminate the ridge or furrow in the center of cut, loosen the U-Bolts holding the bearing connectors (Item 10, Fig. 2) on the rear gang frames. Move all rear disc gang assemblies out if the harrow is leaving a ridge. If the harrow is not filling up the furrow left by the center of the front gangs move all disc gangs in toward the center of unit. Make sure that all disc gangs are moved the same distance toward or away from the center of harrow. Check each consecutive set of disc gangs to see that correct amount of space (8") is between disc. The speed that the harrow is pulled will affect these adjustments, therefore, adjustments should be made for the speed which the harrow will normally be pulled.

Depth of Cut

See Item 4, Fig. 26

The depth of cut is controlled by the use of two ASAE standard 4" x 8" single or double action hydraulic cylinders or by using the depth adjustment bar, cuff, and pin. To adjust the depth of cut using the depth adjustment bar and cuff, slide the depth adjustment cuff forward to decrease the depth of cut, or back to increase the depth of cut. For transport, move the depth adjustment cuff to the foremost hole. Never pin the depth adjustment cuff in front of the slide which the depth adjustment bar travels through on the rear of the harrow. Also, do not place a wedge or any other object between the hydraulic cylinder bracket and the bracket holder welded on the wheel axle.

OPERATING INSTRUCTIONS (Continued)

Tightening of Disc Axles

See Item 7, Fig. 26

The axles and disc gangs are assembled at the factory prior to shipment. The disc axles have been tightened sufficiently at the factory. During the first few hours of operation the discs and disc spacer will seat themselves, which tends to loosen the disc axles. After this initial "run in" the disc axles should be retightened to a minimum of 1000 lb.-ft. Unless the disc axle nut is removed for some reason, no further tightening should be necessary. To check the disc axle for looseness, place the harrow in transport position and strike each disc with a light hammer. If the disc has a ringing sound, the axle is tight.

Lubrication

See Item 5, Fig. 26

The bearings used in the wheel hub assemblies are packed with grease at the factory prior to shipment. These bearings should be checked and adjusted periodically and repacked with grease. The harrow should be greased at all alemite fittings as often as necessary to insure ease of operation and long life of the working parts (Approx. 300 to 400 hrs.). These points are indicated as (Item 5, Fig. 26). The ball bearings used in disc gang assembly are regreasable ball bearings and should be greased daily when operating.

Transporting Harrow

Item 4, 6, Fig. 26

Use the depth control bars when in transport position. Remove depth adjustment pins and cuffs. Raise the unit and insert the pin through the cuff and the hole closest to the front of the unit (Item 4, Fig. 26). With wings folded insert pin (Item 6, Fig. 26) through brackets and wing stop.

ATTACHMENTS

Balk Breaker Attachment

MACHINERY NO. 299082

Remove the four bolts (Item 1, Fig. 9) from the Balk Breaker Connector (Item 4, Fig. 9). Mount the Balk Breaker Attachment on the Center Frame directly behind the Wheel Axle Bearings and secure in place with the four bolts previously removed.

Gang Coupler Attachment

MACHINERY NO. 200092

On the front gang frames, start on the outside and work toward the inside. On the rear gang frames, start on the inside and work toward the outside. This is to give adequate axle clearance to install the gang couplers.

1. Remove the nut, washer and end spacer (Items 1, 2 & 4, Fig. 2) from the axle (Item 14) in the opening where the two axles are to be connected. Slip the axle (Item 14, Fig. 2) back 1" to 1½" to make the opening wide enough to install the coupler.
2. With the bolts provided, mount the butt plate driver (Item 22, Fig. 11) on the butt plate (Item 13, Fig. 2). Tighten all bolts evenly and securely.
3. Replace the end spacer (Item 4, Fig. 2) previously removed with the end washer drive (Item 23, Fig. 11). Slip the axle back into its original position and replace the nut and washer. Tighten securely. Replace cotter. There is no adjustment or maintenance required on the gang coupler.

Furrow Filler Attachment

MACHINERY NO. 200080

Remove the three ½" x 1½" bolts (Item 10, Fig. 10) from each furrow filler spacer (Item 11, Fig. 10). Mount the furrow filler spacers onto the butt-plates (Item 13, Fig. 2) on the outside rear of the harrow. To mount the furrow filler spacers insert the heads of the ½" x 1½" bolts into the three slots provided on the outside of each butt-plate and secure the furrow filler spacers to the butt-plates. Mount the discs (Item 19, Fig. 10) onto the furrow filler spacers and tighten into position, using the furrow filler butt-plates, lock washers and nuts (Items 16, 17, & 18, Fig. 10) provided. Any disc with a ⅜" square center hole can be used. For best results, use a disc that is 4" x 6" smaller than the discs on the harrow.

To mount the Furrow Filler Scrapers (Item 15, Fig. 10) onto the harrow, remove the outside Scrapers (Items 2 & 5, Fig. 4) on the outside rear of the harrow and mount the Furrow Filler Scraper Bars (Item 13, Fig. 10) onto the Scraper Bars (Item 4, Fig. 4) with the side with three holes to the inside. Use the second and third holes to attach the Furrow Filler Scraper Bars. Tighten into position with the Scrapers previously removed. Attach the Furrow Filler Scrapers (Item 15, Fig. 10) to the Furrow Filler Scraper Bars, adjust and tighten all bolts.

INDEX

Basic Frame Parts List	page 2-3
Flange Bearing Conn. Disc Gang Assembly	4
Spring Bearing Conn. Disc Gang Assembly	5
Scraper Bar and Wheel Hub Assembly	6
Hydraulic Assembly	7-8
Balk Breaker and Gang Coupler	9
Bundling List	10-11
Setting-Up Instructions	12-17
Operating Instructions	18-20



SAFETY



General

1. Do not walk on unit.
2. Use extreme caution around disc blades.
3. Do not try to adjust unit while moving.
4. Keep all bolts tight; all pins in place.
5. Do not alter design of unit.

Transporting

1. Use slow-moving emblem.
2. Do not exceed 15 mph.
3. Pin and lock transport bar before moving.
4. Do not transport without keying hitch bolt.
5. Always insert safety lock pin after folding wing.
6. Pull behind farm tractors only.

Folding Wings

1. Do not allow anyone to stand near wings being folded or unfolded.
2. Do not remove hydraulic cylinders without inserting safety pin.

TAYLOR IMPLEMENT DIVISION

PITTSBURGH FORGINGS CO.

TRACTOR DRAWN *Taylor-Way* IMPLEMENTS

ATHENS, TENNESSEE 37303—TELEPHONE (AREA CODE 615) 745-3110